

SPECIFICATIONS



bobcat® 753



Special Features:

- More Horsepower - 40 HP Liquid-Cooled Diesel
- Patented New Cooling System
- Improved Operator Comfort
- Improved Digging Performance
- Simple Customer Maintenance
- Monitor System Continuously Checks Machine Functions and Alerts Operator of Malfunction
- Removable Wheel Hubs for Ease of Service
- Push Button-Activated Auxiliary Hydraulics
- Stronger Structures Improve Service Life
- Full Adaptability to Existing 740 Series Attachments

MELROE COMPANY



A BUSINESS UNIT OF CLARK EQUIPMENT COMPANY



bobcat 753

SPECIFICATIONS

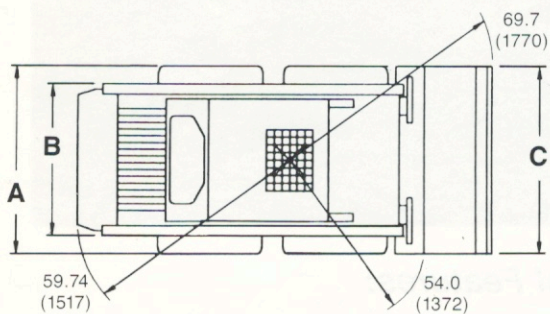
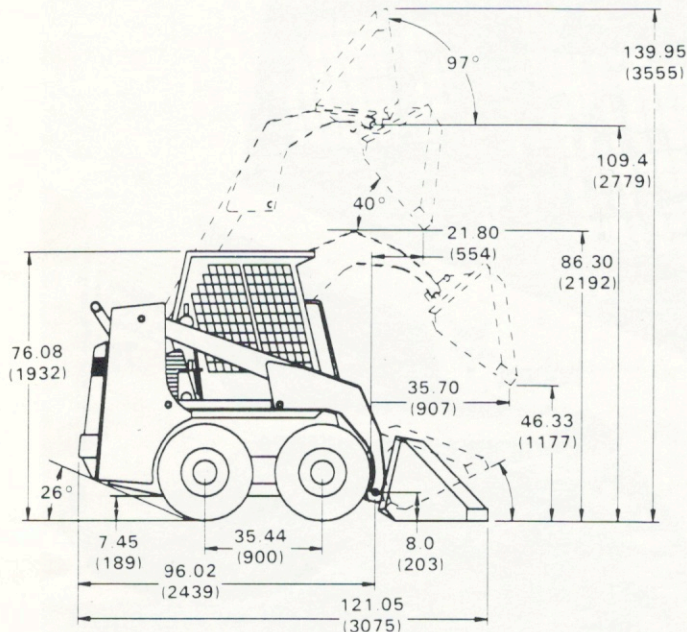

A- Standard Tires-54.0 (1372mm)
Flotation-60.0 (1524mm)

B- Standard Tires-47.0 (1194mm)
Flotation-49.0 (1245mm)

C- Overall Width w/Standard Tires
and 54" Bucket-55.0 (1397mm)
Overall Width w/Flotation Tires
and 60" Bucket-61.0 (1549mm)

Pictures of Bobcat Loaders may show other than standard equipment.
All measurements have their respective metric equivalents enclosed
by parentheses.

*Bucket positioning helps operator keep the same tilt of the load
during lifting.

MELROE COMPANY



A BUSINESS UNIT OF CLARK EQUIPMENT COMPANY

P.O. Box 6019 • Fargo, North Dakota 58108-6019

Society of Automotive Engineers (SAE)
NOTE-Where applicable, dimensions are in
accordance with (SAE) standards.
(Specifications and design are subject to
change without notice.)

753

*NOTICE - Operating capacity rated with standard digging bucket
according to SAE Standard No. J818b-Operating capacity to equal
no more than one half the tipping load.*

CAPACITY

Rated Operating Capacity	LBS	1300
	KG	589.7
Tipping Load	LBS	2612
	KG	1184.8
Hydraulic Pump Capacity	GPM	13.
	LPM	49.2

DIMENSIONS

Length Less Bucket	IN	96.02
	MM	3075
Width Less Bucket	IN	54
	MM	1194
Height	IN	76.1
	MM	1932
Height to Bucket Pin	IN	109.4
	MM	2779

ENGINE

Make	Kubota	
Model	2203 NTCVS	
Fuel	Diesel	
Cylinders	4	
Cylinder Displacement	IN ³	134.2
	Liter	2.2
Fuel Tank Capacity	Gal.	14
	Liter	53

MACHINE WEIGHT

Shipping (W/Standard Tires)	LBS	4330
	KG	1964

OPERATION

Transmission	Hydrostatic
--------------	-------------

SPECIAL FEATURES

Aux. Hydraulics	Std.
Backup Alarm	Opt.
Bob-Tach	Std.
Brakes	Std.
Cab Enclosure	Opt.
Flotation Tires	Opt.
Hydraulic Bucket Positioning*	Opt.
Lift Arm Stop	Std.
Lights	Std.
Monitor System	Std.
Operator Cab	Std.
Polyurethane Paint	Std.
Seat Bar	Std.
Seat Belt	Std.
Spark Arrestor Muffler	Std.
Special Application Kit	Opt.
Suspension Seat	Opt.

ATTACHMENTS

- Angle Broom
- Backhoe and Stabilizer
- Buckets (eleven)
- Combination Bucket
- Earth Auger
- Front Scarifier
- Grapple and Fork
- Hydraulic Breaker
- Landscape Rake
- Pallet Fork
- Sweeper
- Vibratory Roller