

# OPERATOR'S MANUAL

## KUBOTA UTILITY VEHICLE *RTV400*



1A1AACPAP0010

*READ AND SAVE THIS MANUAL*

**Kubota**

RTV400Ci

# ABBREVIATION LIST

| Abbreviations | Definitions  |
|---------------|--|
| 2WD           | Two Wheel Drive  |
| 4WD           | Four Wheel Drive   |
| API           | American Petroleum Institute   |
| ASABE         | American Society of Agricultural and Biological Engineers, USA                             |
| ASTM          | American Society for Testing and Materials, USA  |
| DIN           | Deutsches Institut für Normung, GERMANY  |
| fpm           | Feet Per Minute  |
| Km/h          | Kilometers Per Hour  |
| MPH           | Miles Per Hour   |
| m/s           | Meters Per Second  |
| PTO           | Power Take Off   |
| RH/LH         | Right-hand and left-hand sides are determined by facing in the direction of forward travel |
| ROPS          | Roll-Over Protective Structures  |
| rpm           | Revolutions Per Minute   |
| r/s           | Revolutions Per Second   |
| SAE           | Society of Automotive Engineers, USA   |
| CVT           | Continuously Variable Transmission   |

## California Proposition 65

### **▲ WARNING ▲**

The engine exhaust from this product contains chemicals known to the State of California to cause cancer, birth defects or other reproductive harm.

### **IMPORTANT**

The engine in this machine is equipped by the manufacture with a standard spark arrester.  
It is a violation of California Public Resource Code Section 4442 to use or operate this engine on or near any forest-covered, brush-covered land, or grass-covered land unless the exhaust system is equipped with a working spark arrester meeting state laws. Other states or federal areas may have similar laws.

## **KUBOTA Corporation is ...**

Since its inception in 1890, KUBOTA Corporation has grown to rank as one of the major firms in Japan.

To achieve this status, the company has through the years diversified the range of its products and services to a remarkable extent, until today, 19 plants and 16,000 employees produce over 1,000 different items, large and small.

















All these products and all the services which accompany them, however, are unified by one central commitment. KUBOTA makes products which, taken on a national scale, are basic necessities. Products which are indispensable, products intended to help individuals and nations fulfill the potential inherent in their environment. For KUBOTA is the Basic Necessities Giant.

This potential includes water supply, food from the soil and from the sea, industrial development, architecture and construction, transportation.

Thousands of people depend on KUBOTA's know-how, technology, experience and customer service. You too can depend on KUBOTA.

# UNIVERSAL SYMBOLS

As a guide to the operation of your vehicle, various universal symbols have been utilized on the instruments and controls. The symbols are shown below with an indication of their meaning.

-  Safety Alert Symbol
-  Brake & Parking Brake
-  Battery Charging Condition
-  Engine Oil-Pressure
-  Turn Signal
-  Engine-Stop
-  Engine-Run
-  Engine-Diagnostic
-  Starter Control
-  Differential Lock
-  Master Lighting Switch
-  Headlight
-  Audible Warning Device
-  Four-Wheel Drive-On
-  Four-Wheel Drive-Off
-  Lock
-  Unlock

# FOREWORD

You are now the proud owner of a KUBOTA Vehicle. This vehicle is a product of KUBOTA quality engineering and manufacturing. It is made of excellent materials and under a rigid quality control system. It will give you long, satisfactory service. To obtain the best use of your vehicle, please read this manual carefully. It will help you become familiar with the operation of the vehicle and contains many helpful hints about vehicle maintenance. This manual contains instructions for minor maintenance, but information about major repairs is outlined in the KUBOTA Work Shop Manual and should be performed only by a KUBOTA Dealer Technician. It is KUBOTA's policy to utilize as quickly as possible every advance in our research. The immediate use of new techniques in the manufacture of products may cause some small parts of this manual to become outdated. KUBOTA distributors and dealers will have the most up-to-date information. Please do not hesitate to consult with them.

## SAFETY FIRST

This symbol, the industry's "Safety Alert Symbol", is used throughout this manual and on labels on the machine itself to warn of the possibility of personal injury. Read these instructions carefully. It is essential that you read the instructions and safety regulations before you attempt to assemble or use this unit.



**DANGER :** Indicates an imminently hazardous situation which, if not avoided, will result in death or serious injury.



**WARNING :** Indicates a potentially hazardous situation which, if not avoided, could result in death or serious injury.



**CAUTION :** Indicates a potentially hazardous situation which, if not avoided, may result in minor or moderate injury.

**IMPORTANT :** Indicates that equipment or property damage could result if instructions are not followed.

**NOTE :** Gives helpful information.

# CONTENTS

|   |    |
|---|----|
| ▲ SAFE OPERATION .....  | 1  |
| SERVICING OF VEHICLE.....   | 1  |
| SPECIFICATIONS.....   | 2  |
| SPECIFICATION TABLE .....   | 2  |
| TRAVELING SPEEDS .....  | 3  |
| VEHICLE LIMITATIONS.....  | 4  |
| INSTRUMENT PANEL AND CONTROLS.....                                    | 5  |
| LOCATION OF PARTS.....  | 5  |
| PRE-OPERATION CHECK .....   | 9  |
| DAILY CHECK .....   | 9  |
| OPERATING THE ENGINE.....   | 10 |
| STARTING THE ENGINE .....   | 10 |
| Cold Weather Starting .....   | 12 |
| STOPPING THE ENGINE.....  | 12 |
| WARMING UP .....  | 12 |
| JUMP STARTING .....   | 13 |
| OPERATING THE VEHICLE .....   | 14 |
| OPERATING NEW VEHICLE .....   | 14 |
| Do not Operate the Vehicle at Full Speed for the First 50 Hours ..... | 14 |
| Changing Lubricating Oil for New Vehicles .....                       | 14 |
| STARTING .....  | 14 |
| Seat Belt .....   | 14 |
| Head Light Switch.....  | 15 |
| Horn Button.....  | 15 |
| Brake Pedal .....   | 16 |
| Range Gear Shift Lever .....  | 16 |
| 4WD Lever.....  | 17 |
| Parking Brake Lever .....   | 17 |
| Speed Control Pedal.....  | 17 |
| STOPPING.....   | 18 |
| Stopping.....   | 18 |
| CHECK DURING DRIVING .....  | 18 |
| Immediately Stop the Engine if: .....                                 | 18 |
| Easy Checker(TM).....   | 19 |
| Fuel Gauge .....  | 19 |
| Hourmeter.....  | 20 |
| PARKING .....   | 20 |
| Parking Brake Lever .....   | 20 |
| ACCESSORY .....   | 21 |
| 12V Electric Outlet.....  | 21 |
| OPERATING TECHNIQUES .....  | 21 |
| Differential Lock.....  | 21 |
| Unfamiliar Terrain .....  | 22 |

|   |           |
|---|-----------|
| Driving in Reverse .....                            | 22        |
| Driving in "4WD" .....                              | 23        |
| Turning the Vehicle.....                            | 23        |
| Hills.....  | 24        |
| Traversing Hillsides .....                          | 24        |
| Sliding and Skidding .....                          | 24        |
| Driving through Water.....                          | 25        |
| <b>CARGO BED .....</b>                              | <b>26</b> |
| <b>CARGO BED.....</b>                               | <b>26</b> |
| General Caution.....                                | 26        |
| Max. Cargo Load .....                               | 26        |
| Cargo Bed Tailgate.....                             | 27        |
| Raising and Lowering the Cargo Bed .....            | 28        |
| <b>TIRES AND WHEELS .....</b>                       | <b>29</b> |
| <b>TIRES.....</b>                                   | <b>29</b> |
| Inflation Pressure.....                             | 29        |
| Tire Type and Use .....                             | 29        |
| <b>WHEELS .....</b>                                 | <b>30</b> |
| <b>SHOCK ABSORBERS .....</b>                        | <b>30</b> |
| Rear Shock Absorber Spring Adjustment.....          | 30        |
| <b>TOWING AND TRANSPORTING .....</b>                | <b>31</b> |
| <b>TOWING AND TRANSPORTING .....</b>                | <b>31</b> |
| Rear Trailer Hitch.....                             | 31        |
| Front Trailer Hitch.....                            | 31        |
| Winch Mount Bracket.....                            | 32        |
| <b>MAINTENANCE.....</b>                             | <b>33</b> |
| <b>SERVICE INTERVALS .....</b>                      | <b>33</b> |
| <b>LUBRICANTS AND FUEL.....</b>                     | <b>36</b> |
| <b>PERIODIC SERVICE.....</b>                        | <b>37</b> |
| <b>HOW TO OPEN THE HOOD AND TILT THE SEAT .....</b> | <b>37</b> |
| Hood .....  | 37        |
| Operator's Seat.....                                | 38        |
| <b>HOW TO RAISE THE CARGO BED.....</b>              | <b>38</b> |
| Raising and Lowering the Cargo Bed .....            | 38        |
| <b>JACK-UP POINT .....</b>                          | <b>39</b> |
| Front End .....                                     | 39        |
| Rear End.....                                       | 39        |
| <b>DAILY CHECK .....</b>                            | <b>40</b> |
| Walk Around Inspection.....                         | 40        |
| Checking Amount of Fuel and Refueling .....         | 40        |
| Checking Engine Oil Level.....                      | 41        |
| Checking Transmission Fluid Level .....             | 42        |
| Checking Brake Fluid Level .....                    | 42        |
| Checking Brake Pedal .....                          | 43        |
| Checking Parking Brake .....                        | 43        |
| Checking Gauges, Meter and Easy Checker(TM).....    | 43        |
| Checking Head Light, etc.....                       | 43        |
| Checking Seat Belt and ROPS .....                   | 43        |

---

|  |    |
|--|----|
| Checking Joint Boot.....   | 44 |
| Checking Tire Inflation Pressure.....                                      | 44 |
| EVERY 50 HOURS .....   | 45 |
| Greasing .....   | 45 |
| Checking Engine Start System .....   | 46 |
| EVERY 100 HOURS .....  | 46 |
| Checking Wheel Bolt Torque .....   | 46 |
| Changing Engine Oil.....   | 47 |
| Cleaning Engine Air Cleaner Element .....                                  | 48 |
| Cleaning CVT Air Cleaner Element .....                                     | 48 |
| Checking Spark Plug Condition & Gap.....                                   | 49 |
| Checking Fuel Line .....   | 50 |
| Checking Carbon Canister Air Filter .....                                  | 51 |
| Checking Battery Condition .....   | 51 |
| Adjusting Toe-in.....  | 53 |
| Cleaning Spark Arrester .....  | 54 |
| EVERY 200 HOURS .....  | 54 |
| Adjusting Parking Brake Lever .....  | 54 |
| Replacing Engine Oil Filter .....  | 55 |
| Checking and Cleaning Engine Cooling Air Inlet and Engine Cooling Fin..... | 55 |
| Checking Brake Pedal .....   | 56 |
| Checking Brake Hose and Pipe.....  | 56 |
| Checking Brake Light Switch .....  | 57 |
| Checking Engine Intake Air Line.....                                       | 57 |
| Checking CVT Intake Air Line.....  | 58 |
| Checking CVT Belt .....  | 58 |
| EVERY 300 HOURS .....  | 58 |
| Checking Tire.....   | 58 |
| Adjusting Engine Valve Clearance .....                                     | 58 |
| EVERY 400 HOURS .....  | 59 |
| Changing Transmission Oil.....   | 59 |
| Changing Front Axle Case Oil .....   | 60 |
| EVERY 500 HOURS .....  | 60 |
| Cleaning Engine Combustion Chamber .....                                   | 60 |
| EVERY 1 YEAR .....   | 60 |
| Replacing Engine Air Cleaner Element .....                                 | 60 |
| Replacing CVT Air Cleaner Element .....                                    | 60 |
| EVERY 2 YEARS .....  | 61 |
| Changing Brake Fluid .....   | 61 |
| Replacing Fuel Hose .....  | 61 |
| Replacing Brake Master Cylinder (Inner Parts) .....                        | 61 |
| Replacing Engine Intake Air Line.....                                      | 61 |
| Replacing CVT Intake Air Line.....   | 61 |
| Replacing Engine Breather Hose .....                                       | 61 |
| EVERY 4 YEARS .....  | 61 |
| Replacing Brake Hose .....   | 61 |
| SERVICE AS REQUIRED.....   | 61 |
| Checking Brake Pad .....   | 61 |
| Adjusting Parking Brake .....  | 62 |
| Adjusting Alternator Drive Belt Tension .....                              | 62 |
| Replacing Fuse.....  | 62 |
| Replacing Slow-Blow Fuses .....  | 63 |



|  |    |
|--|----|
| Replacing Light Bulb.....                | 64 |
| STORAGE .....                            | 65 |
| VEHICLE STORAGE .....                    | 65 |
| REMOVING THE VEHICLE FROM STORAGE.....   | 65 |
| TROUBLESHOOTING.....                     | 66 |
| ENGINE TROUBLESHOOTING .....             | 66 |
| BATTERY TROUBLESHOOTING .....            | 68 |
| MACHINE TROUBLESHOOTING .....            | 69 |
| OPTIONS.....                             | 70 |
| ENGINE EMISSION RELATED INFORMATION..... | 71 |



# SAFE OPERATION

Careful operation is your best insurance against an accident.

Read and understand this Operator's Manual carefully before operating the vehicle.

All operators, no matter how much experience they may have, should read this and other related manuals before operating the vehicle or any implement attached to it. It is the owner's obligation to instruct all operators in safe operation.

## 1. BEFORE OPERATING THE VEHICLE

1. Know your equipment and its limitations. Read this entire manual before attempting to start and operate the vehicle.
2. Pay special attention to the Danger, Warning and Caution labels on the vehicle.
3. Do not remove Roll-Over Protective Structures (ROPS) for any application and fasten seat belts at all times. This combination will reduce the risk of serious injury or death, should the vehicle be upset.  
If the ROPS is loosened or removed for any reason, make sure that all parts are reinstalled correctly before operating the vehicle.  
Never modify or repair a ROPS because welding, bending, drilling, grinding, or cutting may weaken the structure.  
A damaged ROPS structure must be replaced, not repaired or revised.  
If any structural member of the ROPS is damaged, replace the entire structure at your local KUBOTA Dealer.

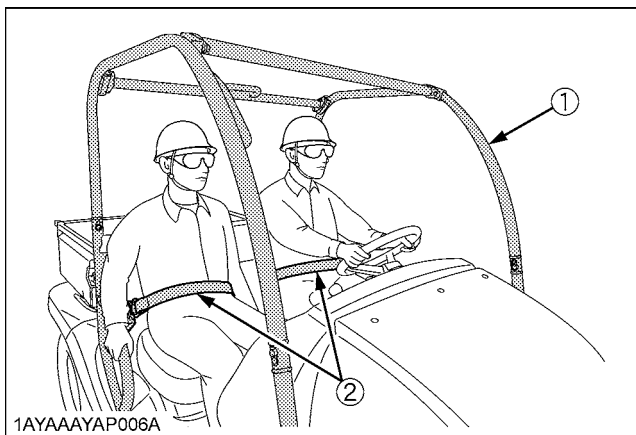

(1) ROPS  
(2) Seat belt

4. Always use the seat belts. Check the seat belts regularly and replace if frayed or damaged.

5. Do not operate the vehicle or any implement attached to it while under the influence of alcohol, medication, controlled substances or while fatigued.
6. Carefully check the vicinity before operating the vehicle or any implement attached to it. Check for overhead clearance which may interfere with the CAB or ROPS. Do not allow any bystanders around or near the vehicle during operation.
7. Never allow anyone without a valid driver's license to operate this vehicle.
8. Before allowing other people to use your vehicle, explain how to operate and have them read this manual before operation.
9. Never wear loose, torn, or bulky clothing around the vehicle. It may catch on moving parts or controls, leading to the risk of an accident. Use additional safety items, e.g. helmet, safety boots or shoes, eye and hearing protection, gloves, etc., as appropriate or required.
10. This vehicle is for off road use only.  
KUBOTA does not recommend operating on public roads.
11. In addition to the driver, only one passenger should ride in the vehicle.  
Minimum age for passenger is 5 years old.
12. Keep all shields in place and stay away from all moving parts.
13. Check brakes, speed control pedal, and other mechanical parts for improper adjustment and wear.  
Replace worn or damaged parts promptly. Check the tightness of all nuts and bolts regularly. (For further details, see "MAINTENANCE" section.)
14. Keep your vehicle clean. Dirt, grease, and trash build up may contribute to fires and lead to personal injury.
15. Use only implements meeting the specifications listed under "VEHICLE LIMITATIONS" in this manual or implements approved by KUBOTA.
16. The maximum cargo capacity of this vehicle is 200kg.  
Reduce cargo capacity to match operating conditions.  
Do not carry anything which raises the center-of-gravity and sticks outside the cargo bed.
17. Do not modify the vehicle. Unauthorized modification may affect the function of the vehicle, which may result in personal injury.

## 2. OPERATING THE VEHICLE

### ◆ Starting

1. Always sit in the operator's seat when starting engine or operating levers or controls.
2. Before starting the engine, make sure that all levers are in their neutral positions, that the parking brake is engaged.
3. Do not start engine by shorting across starter terminals or bypassing the safety start switch. The vehicle may start in gear and move if normal starting circuitry is bypassed.
4. Be sure that the operator (and passenger) seat belts are fastened.
5. Do not operate or idle engine in a non-ventilated area. Carbon monoxide gas is colorless, odorless, and deadly.

### ◆ Operating

1. Do not wear headphones while operating.
2. Pull only from the trailer hitch (if equipped). Never hitch to axle housing or any other point except trailer hitch; such arrangements will increase the risk of serious personal injury or death due to a vehicle upset.

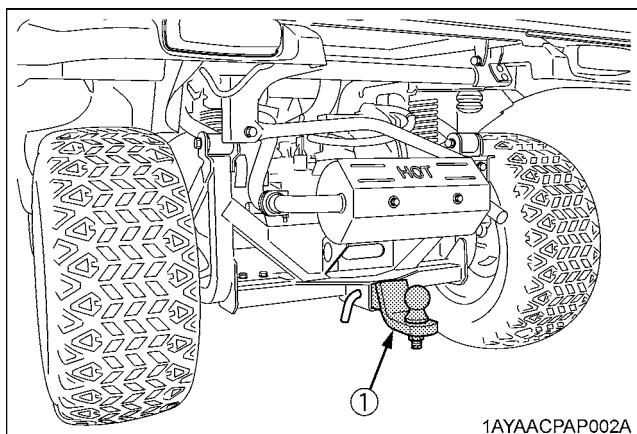

(1) Trailer hitch (if equipped)

3. Keep all shields and guards in place. Replace any that are missing or damaged.
4. Avoid sudden starts. To avoid upsets, slow down when turning, on uneven ground, and before stopping.
5. The vehicle cannot turn with the differential locked and attempting to do so could be dangerous.
6. Do not operate near ditches, holes, embankments, or other ground surface features which may collapse under the vehicle's weight. The risk of vehicle upset is even higher when the ground is loose or wet.
7. Watch where you are going at all times. Watch for and avoid obstacles. Be alert at row ends, near trees, and other obstructions.
8. When working in groups, always let the others know what you are going to do before you do it.
9. Never try to get on or off a moving vehicle.

### ◆ Safety for children

Tragedy can occur if the operator is not alert to the presence of children. Children generally are attracted to vehicles and the work they do.

1. Never assume that children will remain where you last saw them.
2. Keep children out of the work area and under the watchful eye of another responsible adult.
3. Be alert and shut your vehicle down if children enter the work area.
4. Never carry children in the cargo bed. There is no safe place for them to ride. No person under the age of 5 may ride as a passenger in this vehicle. A passenger under 5 years of age requires special restraints which are not available with this vehicle.
5. Never allow children to operate the vehicle even under adult supervision.
6. Never allow children to play on the vehicle or on the implement.
7. Use extra caution when backing up. Look behind and down to make sure area is clear before moving.
8. Whenever possible, park your vehicle on a firm, flat and level surface. If this is not possible, park it across the slope. Set the parking brake(s), lower the implements to the ground, remove the key from the ignition and chock the wheels.

### ◆ Operating on slopes

Slopes are a major factor related to loss-of-control and tip-over accidents, which can result in severe injury or death. All slopes require extra caution.

1. Travel straight up or down hill.
2. Reduce load when operating on hilly or over rough terrain.
3. Keep front wheels straight at crest of hill or going over bumps.
4. Do not stop or start suddenly when going uphill or downhill. Be especially cautious when changing direction on slopes.
5. If vehicle stops or loses power going up a hill, lock parking brake to hold vehicle on slope. Maintain direction of travel and release brake slowly. Back straight downhill while maintaining control. Do not turn vehicle sideways. Vehicle is more stable in a straight forward or rearward position.
6. When riding on soft terrain, turn front wheels slightly uphill to keep vehicle on a straight line across the hill.
7. If the vehicle begins to tip, turn front wheels downhill to gain control before proceeding.
  - (1) To avoid upsets, always back up steep slopes. If you cannot back up the slope or if you feel uneasy on it, do not operate on it. Stay off slopes too steep for safe operation.

- (2) Driving forward out of a ditch, mired condition or up a steep slope increases the risk of a vehicle to be upset backward. Always back out of these situations. Extra caution is required with four-wheel drive mode because the increased traction can give the operator false confidence in the vehicle's ability to climb slopes.
- (3) Keep all movement on slopes slow and gradual. Do not make sudden changes in speed or direction.

#### ◆ Operation in inclement conditions

1. Only operate during daylight or with good artificial light.
2. Operate vehicle in an open, unobstructed area.
3. Use helmet and/or protective gear for certain operating conditions.
4. Reduce speed according to trail, terrain and visibility conditions.
5. Never drive exceeding the limit of visibility. Slow down near crest of hill until getting a clear view of the other side.
6. Stay alert for holes, rocks and other hidden hazards in the terrain.
7. Never cross any body of water where depth may be unknown to the operator (Deep water is considered anything above the bottom edge of the axle cap). Choose a course within the waterway where both banks have a gradual incline. Cross at a point known to be safe.

#### ◆ Driving the vehicle at high speeds

1. Check the front wheel engagement. The braking characteristics are different between two and four wheel drive. Be aware of the difference and use carefully.
2. Always slow the vehicle down before turning. Turning at high speed may tip the vehicle over.
3. Turn the headlights on.
4. Drive at speeds that allow you to maintain control at all times.
5. Do not apply the differential lock while traveling at high speeds. The vehicle may run out of control.
6. Avoid sudden motions of the steering wheel as they can lead to a dangerous loss of stability. The risk is especially great when the vehicle is traveling at high speeds.

#### ◆ Other miscellaneous

1. Clean platform if dirty and remove any debris from around foot controls.
2. Always keep both hands on the steering wheel.
3. Always keep arms and legs inside the operating compartment.
4. Never operate the vehicle while standing.
5. Do not tow a cart with any riders on it.
6. Never attempt wheelies, jumps or other stunts.

### 3. HAULING LOADS IN THE CARGO BED

1. No riders in cargo bed or anywhere else.
2. Do not overload vehicle. Securely anchor all loads.
3. Be sure load is evenly distributed.
4. Reduce cargo capacity when operating on rough or hilly terrain.
5. Balance loads evenly and secure them. Braking could shift the load and affect vehicle stability.
6. Never operate vehicle with the cargo bed raised.
7. Operate cargo bed dump with vehicle stationary and parking brake locked. Do not dump while moving.
8. Operate the cargo bed dump on level ground only.
9. Do not place hands or body under the cargo bed when lowering bed.

### 4. PARKING THE VEHICLE

1. Lower all implements to the ground, place all control levers in their neutral positions, set the parking brake, stop the engine, and remove the key.
2. Make sure that the vehicle has come to a complete stop before dismounting.
3. Avoid parking on steep slopes, if possible park on flat ground, if not, park across a slope, always with attachment on the ground.

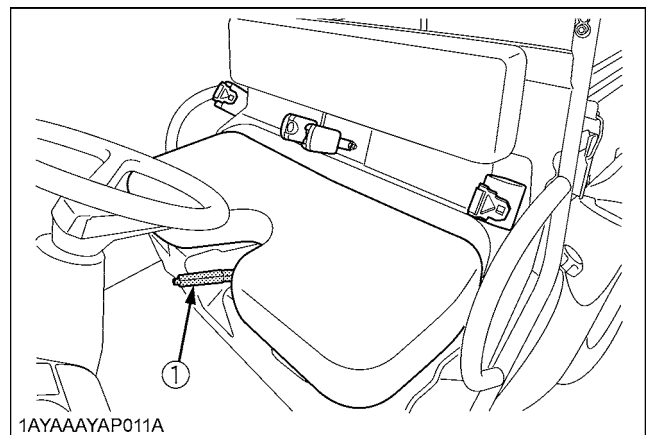

(1) Parking brake lever

### 5. TRANSPORTING

1. Disengage power to attachment(s) when transporting or not in use.
2. Do not tow this vehicle. Use a suitable truck or trailer when transporting on public roads.
3. Use extra care when loading or unloading the vehicle into a trailer or truck.

## 6. SERVICING THE VEHICLE

Before servicing the vehicle, park it on a firm, flat and level surface, set the parking brake, lower all implements to the ground, place the range gear shift lever in neutral, stop the engine and remove the key.

1. Allow the vehicle time to cool off before working on or near the engine, muffler, radiator, etc.
2. Always stop the engine before refueling. Avoid spills and overfilling.
3. Do not smoke when working around battery or when refueling. Keep all sparks and flames away from battery and fuel tank. The battery presents an explosive hazard, because it gives off hydrogen and oxygen especially when recharging.
4. Before "jump starting" a dead battery, read and follow all of the instructions. (See "JUMP STARTING" in "OPERATING THE ENGINE" section.)
5. Keep first aid kit and fire extinguisher handy at all times.
6. Disconnect the battery's ground cable before working on or near electric components.
7. To avoid the possibility of battery explosion, do not use or charge the refillable type battery if the fluid level is below the LOWER (lower limit level) mark. Check the fluid level regularly and add distilled water as required so that the fluid level is between the UPPER and LOWER marks.
8. To avoid sparks from an accidental short circuit, always disconnect the battery's ground cable (-) first and reconnect it last.

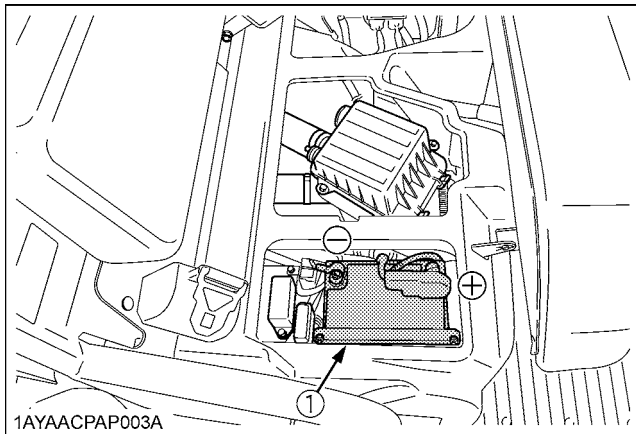

(1) Battery

9. Do not attempt to mount a tire on a rim. This should be done by a qualified person with the proper equipment.
10. Always maintain the correct tire pressure. Do not inflate tires above the recommended pressure shown in the operator's manual.



11. Securely support the vehicle when changing wheels.
12. Make sure that wheel bolts have been tightened to the specified torque.

## 7. DANGER, WARNING AND CAUTION LABELS

(1) Part No. K7311-6565-1



1AYAAAYAP0920

(2) Part No. K7311-6522-1

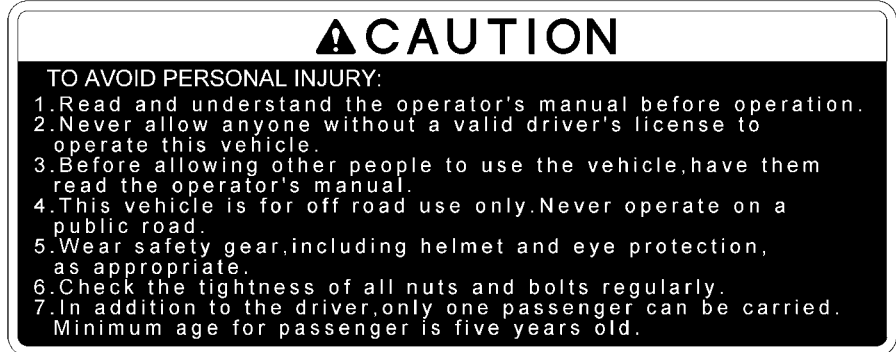

1AYAAAYAP0930

(3) Part No. K7311-6533-4



1AYAAAYAP0960

(4) Part No. K7311-6524-1

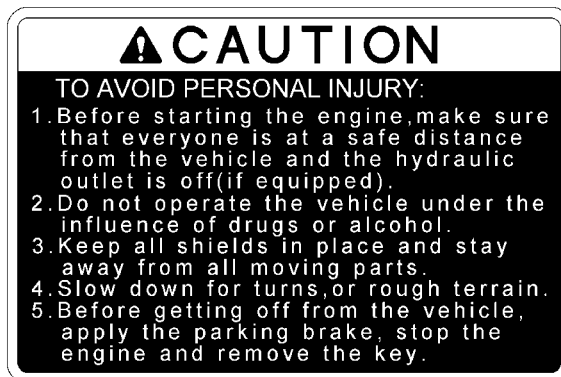

1AYAAAYAP0950

(5) Part No. K7311-6530-1



1AYAAAYAP0940

1AYAACAP050A

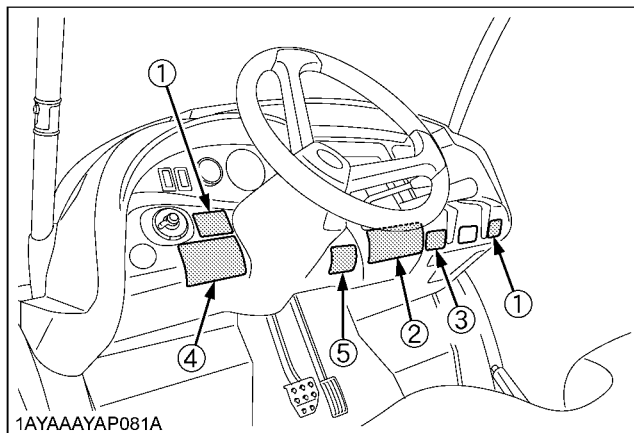

1AYAAAYAP081A

(1) Part No. K7211-6525-1



## ⚠ DANGER

**TO AVOID POSSIBLE INJURY OR DEATH FROM A MACHINE RUNAWAY:**

1. Do not start engine by shorting across starter terminals or bypassing the safety start switch. The vehicle may start in gear and move if normal starting circuitry is bypassed.
2. Start engine only from operator's seat with range shift lever in neutral position and hydraulic outlet off (if equipped).

1AYAAAYAP0970

(2) Part No. K7561-6541-2

## ⚠ WARNING



**TO AVOID PERSONAL INJURY OR DEATH:**

1. Do not remove Roll-Over Protective Structures (ROPS) for any application.
2. Do not modify or repair a ROPS because welding, grinding, drilling or cutting any portion may weaken the structure.

1AYAAAYAP0980

(3) Part No. K7311-6537-1

Gasoline  
fuel only No fire





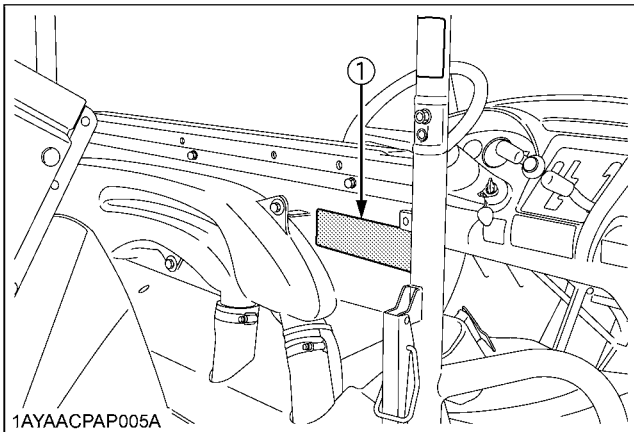

GASOLINE ONLY

1AYAAAYAP1000

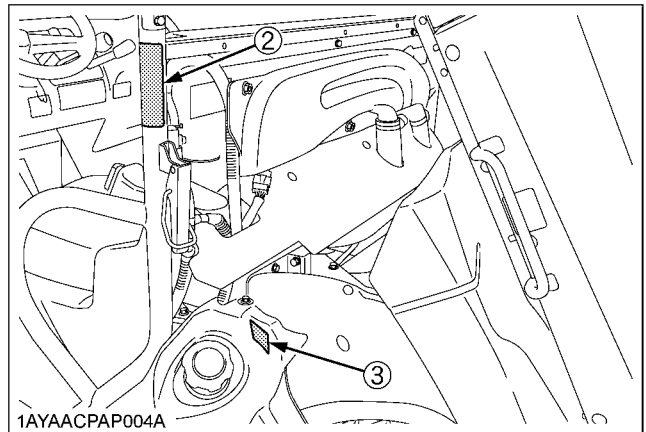

1AYAAC PAP051A



|  |  |
|--|--|
| <b>⚠ WARNING</b>   | <b>⚠ CAUTION</b>   |
|  <p><b>TO AVOID PERSONAL INJURY:</b></p> <ol style="list-style-type: none"> <li>1. Do not place gas container inside cargo box bed when filling.</li> <li>2. Place gas container on ground when filling.</li> </ol> | <p><b>TO AVOID PERSONAL INJURY:</b></p> <ol style="list-style-type: none"> <li>1. Before touching any part of an exhaust system, be absolutely sure that it has had sufficient time to cool.</li> <li>2. Always wear safety goggles and a (face)mask.</li> <li>3. The particulate matter contained in the muffler contains chemicals that are harmful to people, animal and marine life.</li> <li>4. If you are unable to do this work, have it done by your KUBOTA Dealer.</li> </ol> |

(1) Part No. K7211-6526-2

|   |  |   |  |  |   |
|---|--|---|--|--|---|
| <p><b>⚠ WARNING</b></p> <p><b>TO AVOID PERSONAL INJURY:</b></p> <ol style="list-style-type: none"> <li>1. Do not carry passengers in cargo bed.</li> <li>2. Do not travel with the cargo bed in the raised position.</li> </ol> | <p><b>⚠ WARNING</b></p>  <p><b>TO AVOID PERSONAL INJURY:</b></p> <ol style="list-style-type: none"> <li>1. Do not place gas container inside cargo box bed when filling.</li> <li>2. Place gas container on ground when filling.</li> </ol> | <p><b>⚠ CAUTION</b></p> <p><b>TO AVOID PERSONAL INJURY:</b></p> <p>Do not raise the cargo bed while the engine is running above low idle.</p> | <p><b>⚠ CAUTION</b></p> <p><b>TO AVOID PERSONAL INJURY:</b></p> <ol style="list-style-type: none"> <li>1. Before touching any part of an exhaust system, be absolutely sure that it has had sufficient time to cool.</li> <li>2. Always wear safety goggles and a (face)mask.</li> <li>3. The particulate matter contained in the muffler contains chemicals that are harmful to people, animal and marine life.</li> <li>4. If you are unable to do this work, have it done by your KUBOTA Dealer.</li> </ol> | <p><b>⚙ Maintenance</b></p> <p>The screen type spark arrester should be removed, cleaned, and inspected after every 100 hours of use.</p> <ol style="list-style-type: none"> <li>1. The spark arrester is installed to the muffler with bolts.</li> <li>2. Loosen the bolts and remove the spark arrester.</li> <li>3. Some particles off the screen and lightly clean the screen with a wire brush. Do not solvent clean with a wire brush again, if necessary.</li> <li>4. If any brackets is found in the screen or weldments, replace the assembly with new one.</li> <li>5. Reinstall the spark arrester to the muffler and tighten the bolts.</li> </ol> | <p><b>IMPORTANT</b></p> <ol style="list-style-type: none"> <li>1. Max cargo load should not exceed 5000* or 10000*.</li> <li>2. TO AVOID TAILGATE DAMAGE: Remove the rear tow hitch when Tailgate Straps Wire is removed and cargo bed is raised.</li> </ol> <p><b>CBC (Cargo Bed Capacity):</b><br/>200kg (440 lb)<br/>Q2 (Cargo Load)<br/>May vary on models. Refer to operator's manual for details.<br/>Ex: M1000 model: 400kg (880 lb) (operator+passenger+opt. acc. r/cabin weight)</p> |
|---|--|---|--|--|---|

1AYAACPAP049A

**⚠ WARNING**

**TO AVOID PERSONAL INJURY:**

1. Do not carry passengers in cargo bed.
2. Do not travel with the cargo bed in the raised position.

**⚠ CAUTION**

**TO AVOID PERSONAL INJURY:**

Do not raise the cargo bed while the engine is running above low idle.

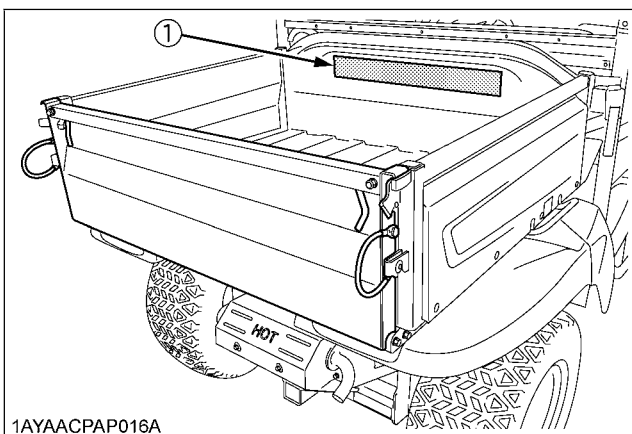

1AYAACPAP016A

1AYAACPAP052A



(1) Part No. K7311-6542-2

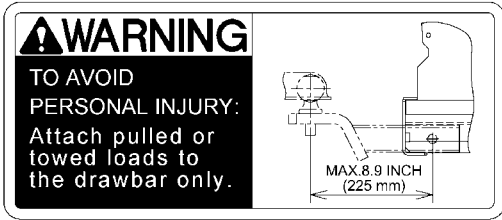

1AYAAAYAP1010

(2) Part No. K7311-6559-1



1AYAAAYAP156A

(3) Part No. K7311-6548-2

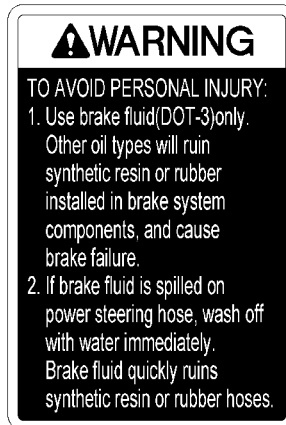

1AYAAAYAP132A

(4) Part No. K2651-6568-1



1AYAACAP1000

(5) Part No. K1221-6118-1

|   |  |  |   |
|---|--|--|---|
| <p><b>MAINTENANCE FREE • SANS ENTRETIEN • LIBRE DE MANTENIMIENTO</b></p> <p><b>⚠ DANGER/POISON ¡PELIGRO/VENENO!</b></p>   |  |  |   |
| <p><b>SHIELD EYES.</b><br/>EXPLOSIVE GASES CAN CAUSE BLINDNESS OR INJURY.</p>   | <p><b>NO</b><br/>• SPARKS<br/>• FLAMES<br/>• SMOKING</p>                   | <p><b>SULFURIC ACID</b><br/>CAN CAUSE BLINDNESS OR SEVERE BURNS.<br/><b>ACIDE</b><br/>PEUT CAUSER LA CECITE OU DES BRULURES.</p> | <p><b>FLUSH EYES IMMEDIATELY WITH WATER. GET MEDICAL HELP FAST.</b><br/><b>RINCEZ LES YEUX A L'EAU IMMEDIATEMENT. CONSULTEZ UN MEDECIN RAPIDEMENT.</b></p>  |
| <p><b>PROTEGEZ LES YEUX.</b><br/>LES GAZ EXPLOSIFS PEUVENT BLESSEZ OU RENDRE AVEUGLE.</p>   | <p><b>ÉVITER</b><br/>• LES ÉTINCELLES<br/>• LES FLAMMES<br/>• DE FUMER</p> | <p><b>ACIDO</b><br/>SULFURICO PUEDE CAUSAR CEGUERA O QUEMADURAS FUERTES.</p>   | <p><b>ENJUAGUE LOS OJOS INMEDIATAMENTE CON AGUA. ACUDA RAPIDO CON EL MEDICO.</b></p>  |
| <p><b>PROTEJA LOS OJOS.</b><br/>LOS GASES EXPLOSIVOS PUEDEN CAUSAR DANOS O CEGUERA.</p>   | <p><b>NO</b><br/>• CHISPAS<br/>• FLAMAS<br/>• CIGARRROS</p>                | <p><b>SULFURICO</b><br/>PUEDE CAUSAR CEGUERA O QUEMADURAS FUERTES.</p>   | <p><b>KEEP OUT OF THE REACH OF CHILDREN. DO NOT TIP. DO NOT OPEN BATTERY!</b><br/><b>TENIR HORS DE LA PORTEE DES ENFANTS. NE PAS RENSERSE. NE PAS OUVRIR LA BATTERIE!</b><br/><b>ALÉJASE DEL ALCANCE DE LOS NIÑOS. NO VOLTEAR. NO ABRIR LA BATERIA!</b></p> |
| <p><b>CALIFORNIA PROPOSITION 65 WARNING:</b> Batteries, battery posts, terminals and related accessories contain lead and lead compounds, and other chemicals known to the State of California to cause cancer and birth defects or other reproductive harm. WASH HANDS AFTER HANDLING.</p> |  |  |   |
| <p>Si la mise en service de cette batterie s'effectue après la date indiquée, vérifiez toujours qu'il n'y a pas de ampères pendant 1 heure. Si la batterie se présente en service depuis 60 la veille que ses caractéristiques, gardez-la pendant un minimum de 1 heure à 6-10 ampères.</p> |  |  | <p>PART NO.<br/>CCA CA</p>  |
| <p>3-7245</p>   |  |  |   |

1BDABDMAP013A

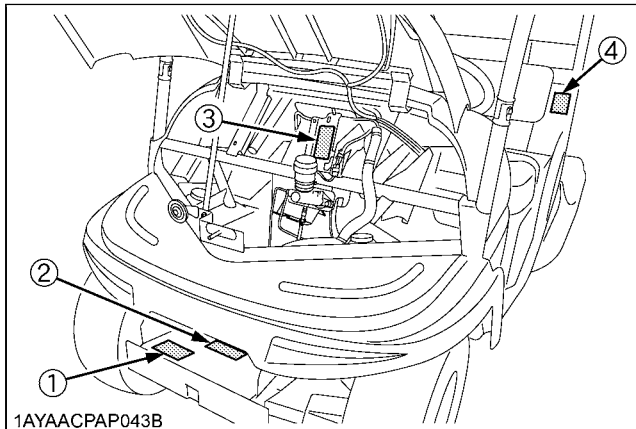

1AYAACAP043B

1AYAACAP053A

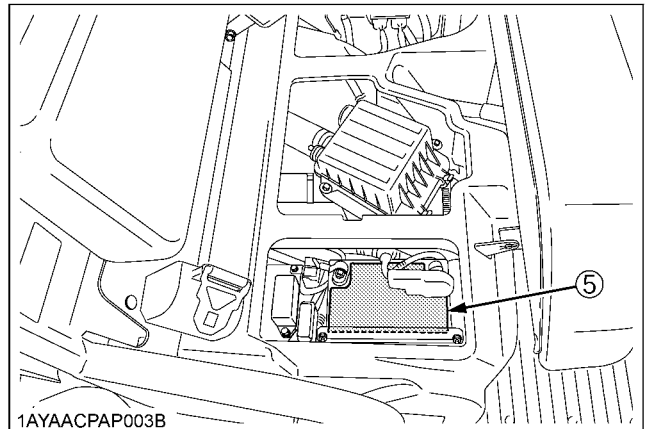

1AYAACAP003B

(1) Part No. K7211-6546-1

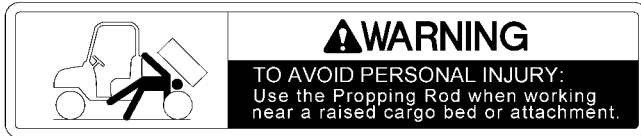

1AYAAAYAP1020

(2) Part No. K7311-6547-2

Do not touch hot surface like muffler, etc.

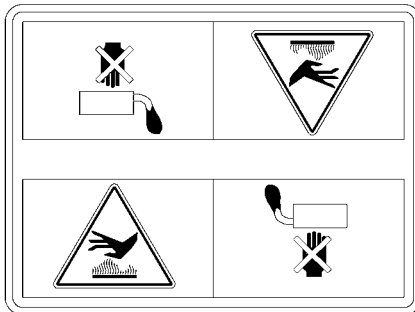

1AYAAAYAP1030

(3) Part No. K7211-6544-1



1AYAAPAP055A

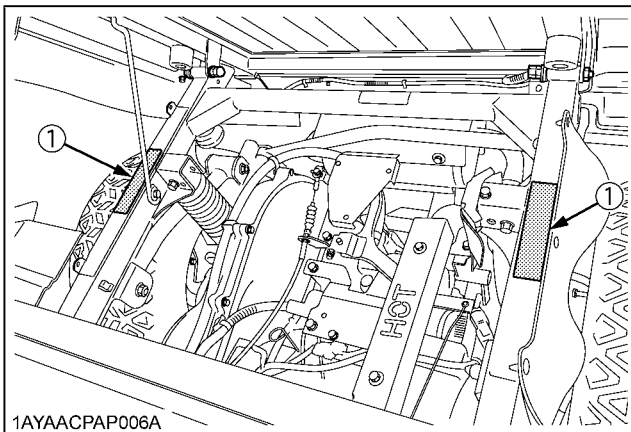

1AYAAPAP006A

1AYAAPAP054A

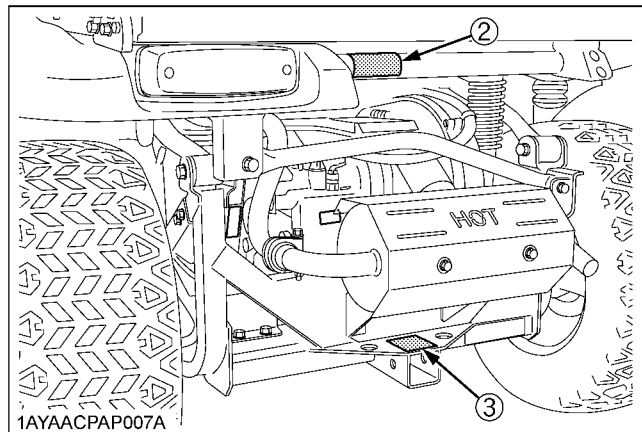

1AYAAPAP007A

## 8. CARE OF DANGER, WARNING AND CAUTION LABELS

1. Keep danger, warning and caution labels clean and free from obstructing material.
2. Clean danger, warning and caution labels with soap and water, dry with a soft cloth.
3. Replace damaged or missing danger, warning and caution labels with new labels from your local KUBOTA Dealer.
4. If a component with danger, warning and caution label(s) affixed is replaced with new part, make sure new label(s) is(are) attached in the same location(s) as the replaced component.
5. Mount new danger, warning and caution labels by applying on a clean dry surface and pressing any bubbles to outside edge.



# SERVICING OF VEHICLE

Your dealer is interested in your new vehicle and has the desire to help you get the most value from it. After reading this manual thoroughly, you will find that you can do some of the regular maintenance by yourself.

However, when in need of parts or major service, be sure to see your KUBOTA Dealer.

For service, contact the KUBOTA Dealership from which you purchased your vehicle or your local KUBOTA Dealer.

When in need of parts, be prepared to give your dealer vehicle, engine, transmission and ROPS serial numbers. Locate the serial numbers now and record them in the space provided.

|  | Type | Serial No. |
|--|------|------------|
| Vehicle  |      |            |
| Engine   |      |            |
| Transmission                                     |      |            |
| ROPS   |      |            |
| Product Identification Number                    |      |            |
| Date of Purchase                                 |      |            |
| Name of Dealer<br>(To be filled in by purchaser) |      |            |

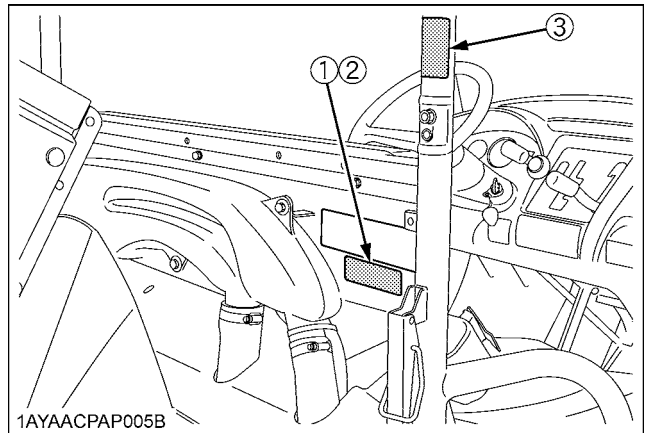

- (1) Vehicle serial number
- (2) Vehicle identification number
- (3) ROPS serial number

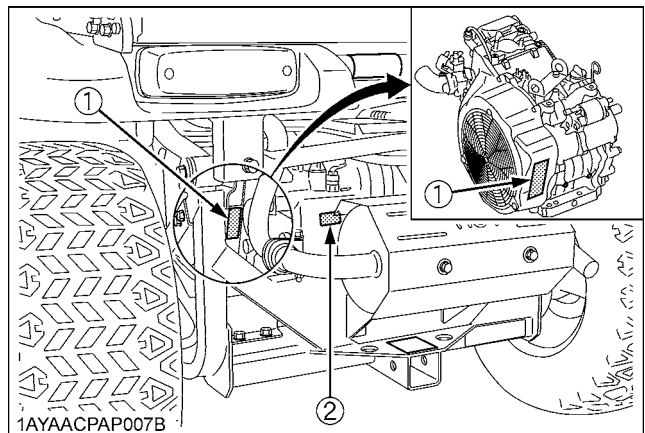

- (1) Engine serial number
- (2) Transmission assy serial number

# SPECIFICATIONS

## SPECIFICATION TABLE

| Model                                 |                       |                         | RTV400Ci   |           |
|---------------------------------------|-----------------------|-------------------------|--|-----------|
| Engine                                | Model                 |                         | SUBARU GH4120  |           |
|                                       | Type                  |                         | 1 cylinder OHC, Air-cooled, EFI Gas                    |           |
|                                       | Displacement          | L (cu. in.)             | 0.404 (24.7)   |           |
| Fuel Capacity                         |                       | L (U.S.gals)            | 20 (5.3)   |           |
| Transmission                          |                       |                         | Continuously variable transmission (CVT)               |           |
| Wheels, Drive system                  |                       |                         | 4, Rear 2WD or 4WD                                     |           |
| Differential lock                     |                       |                         | Standard; hand operated with mechanical holder         |           |
| Gear selection                        |                       |                         | Hi-Lo range forward, neutral, reverse                  |           |
| Brakes                                | Front / Rear          |                         | Dry disk brake   |           |
|                                       | Parking brake         |                         | Rear wheel, hand lever                                 |           |
| Steering                              |                       |                         | Rack & Pinion  |           |
| Suspension                            | Front                 |                         | Independent, MacPherson strut-type                     |           |
|                                       | Rear                  |                         | Semi-independent, Multi-link                           |           |
| Dimensions                            | Length                | mm (in.)                | 2690 (105.9)   |           |
|                                       | Width                 | mm (in.)                | 1390 (54.7)  |           |
|                                       | Height, overall       | mm (in.)                | 1829 (72)  |           |
|                                       | Front tread centers   | mm (in.)                | 1016 (40)  |           |
|                                       | Rear tread centers    | mm (in.)                | 1041 (41)  |           |
|                                       | Wheelbase             | mm (in.)                | 1800 (70.9)  |           |
|                                       | Ground clearance      | front axle              | mm (in.)   | 205 (8.1) |
|                                       |                       | rear axle               |  | 175 (6.9) |
| Turning diameter                      | m (ft)                | 7 (22.9)                |  |           |
| Max. rolling weight (Towing Capacity) |                       | kg (lbs.)               | Rear: 500 (1102) / Front: 250 (551)                    |           |
| Payload capacity                      |                       | kg (lbs.)               | 480 (1058)   |           |
| Weight                                |                       | kg (lbs.)               | 565 (1246) with ATV Tires / 570 (1257) with HDWS Tires |           |
| Cargo bed                             | Width                 | mm (in.)                | 1032 (40.6)  |           |
|                                       | Length                | mm (in.)                | 856 (33.7)   |           |
|                                       | Depth                 | mm (in.)                | 290 (11.4)   |           |
|                                       | Volume                | m <sup>3</sup> (cu.ft.) | 0.25 (9)   |           |
|                                       | Bed height (unloaded) | mm (in.)                | 810 (31.9)   |           |
|                                       | Max. cargo bed load   | kg (lbs.)               | 200 (441)  |           |

| Model              |       | RTV400Ci               |                       |
|--------------------|-------|------------------------|-----------------------|
| Tires              | Front | 24x9-12<br>HDWS, 6PLY  | 24x9-12<br>ATV, 6PLY  |
|                    | Rear  | 24x11-12<br>HDWS, 6PLY | 24x11-12<br>ATV, 6PLY |
| Front deluxe guard |       | Opt.                   |                       |
| Body color         |       | Orange / Camo          |                       |
| Speedometer        |       | Opt.                   |                       |
| Rear net           |       | Opt.                   |                       |

**NOTE :**

- The company reserves the right to change the specifications without notice.
- The values in "Ground clearance" and "Weight" are those of the machine equipped with the tires in the table above.

## TRAVELING SPEEDS

|                           | Gear position | Traveling speeds<br>km/h (mph) |
|---------------------------|---------------|--------------------------------|
| Range gear<br>shift lever | Low           | 24 (15)                        |
|                           | High          | 40 (25)                        |
|                           | Reverse       | 24 (15)                        |

# VEHICLE LIMITATIONS

The KUBOTA Vehicle has been thoroughly tested for proper performance with implements sold or approved by KUBOTA. Use with implements which are not sold or approved by KUBOTA and which exceed the maximum specifications listed below, or which are otherwise unfit for use with the KUBOTA Vehicle may result in malfunctions or failures of the vehicle, damage to other property and injury to the operator or others. [Any malfunctions or failures of the vehicle resulting from use with improper implements are not covered by the warranty]

| Max. Cargo loading weight (W1)   | Rear trailer hitch                             | Front trailer hitch                           |
|--|--|---|
| Max. Cargo load should not exceed "200 kg (441 lbs.)" or "CL".<br><br>CL = 480 kg (1058 lbs.) - (operator + passenger + opt. + acc. + cabin) weight<br><br>CL: Cargo Load<br>opt.: option<br>acc.: accessory | Max. rolling weight (W2)<br>500 kg (1102 lbs.) | Max. rolling weight (W4)<br>250 kg (551 lbs.) |
|  | Max. tongue weight (W3)<br>50 kg (110 lbs.)    | Max. tongue weight (W5)<br>50 kg (110 lbs.)   |

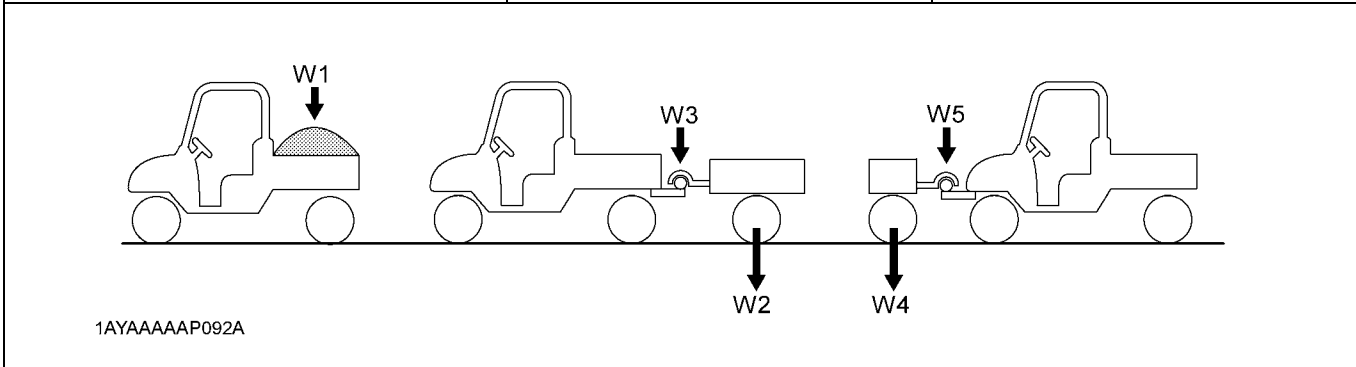

Rolling weight: Trailer weight + Cargo Load

- Above mentioned specifications are based on level ground condition.

# INSTRUMENT PANEL AND CONTROLS

## LOCATION OF PARTS

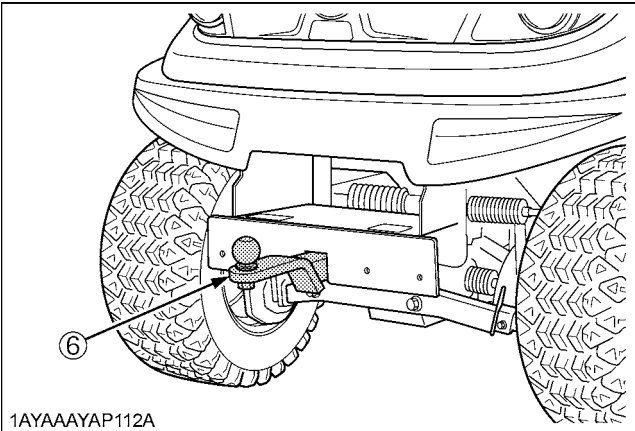
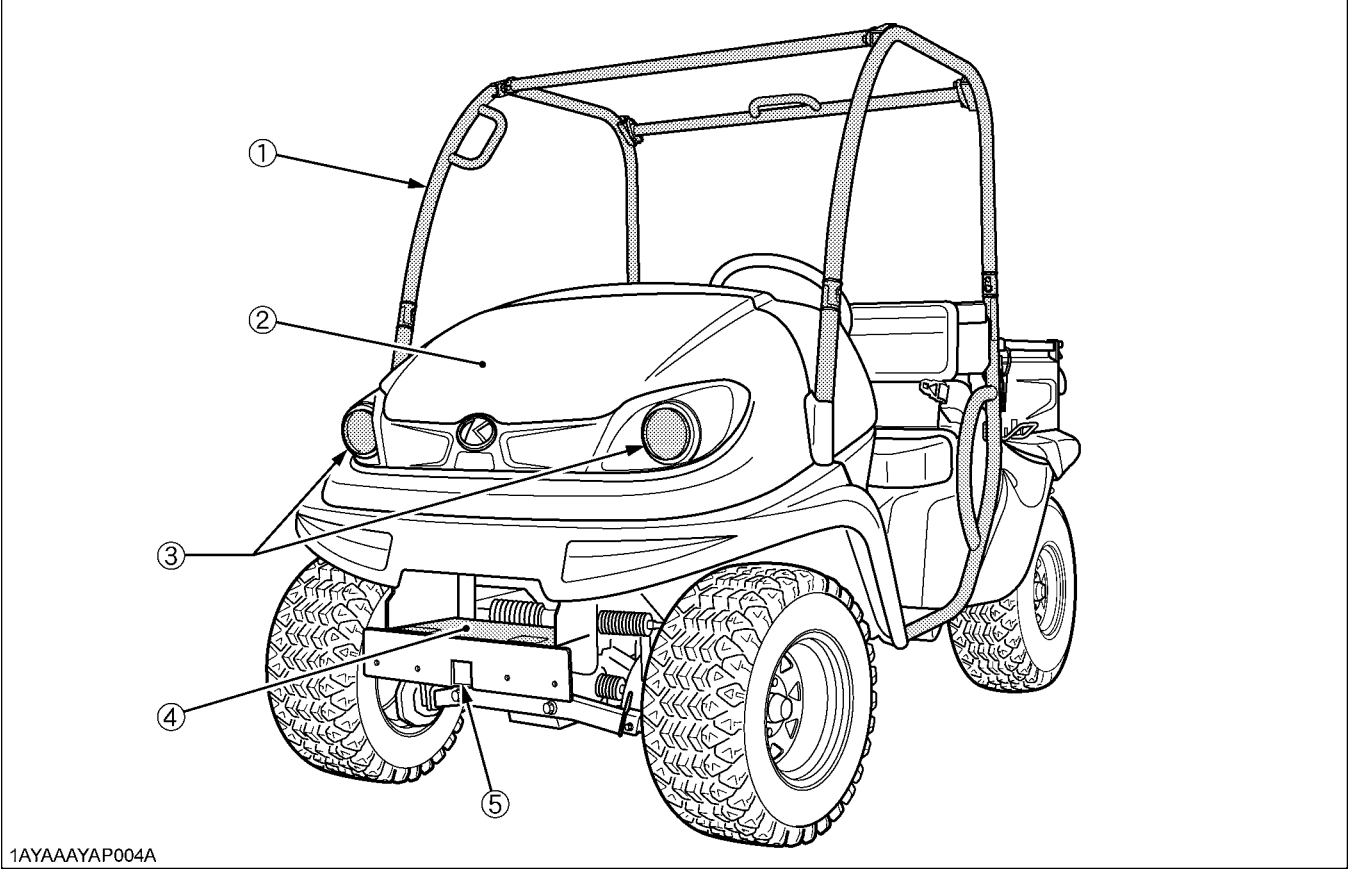

### ILLUSTRATED CONTENTS

|  |    |
|--|----|
| (1) ROPS.....                              | -- |
| (2) Front hood.....                        | 37 |
| (3) Headlights.....                        | 15 |
| (4) Winch mount bracket (if equipped)..... | 32 |
| (5) Front trailer hitch bracket.....       | 31 |
| (6) Front trailer hitch (if equipped)..... | 31 |



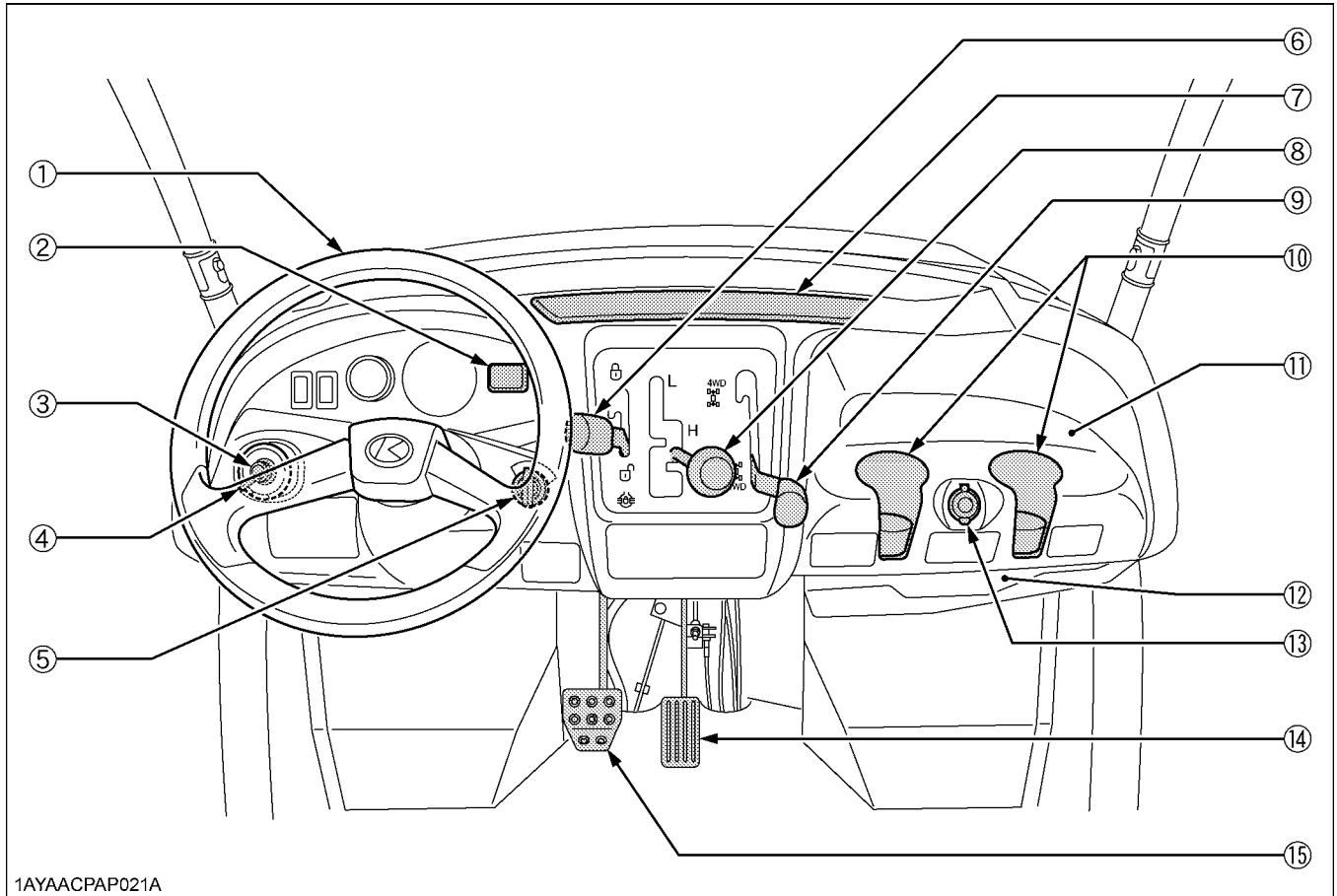

1AYAACPAP021A

ILLUSTRATED CONTENTS

|                                    |    |
|------------------------------------|----|
| (1) Steering wheel.....            | -- |
| (2) Hourmeter.....                 | 20 |
| (3) Horn button.....               | 15 |
| (4) Head light switch.....         | 15 |
| (5) Key switch.....                | -- |
| (6) Differential lock lever.....   | 21 |
| (7) Easy Checker(TM).....          | 19 |
| (8) Range gear shift lever.....    | 16 |
| (9) 4WD lever.....                 | 17 |
| (10) Cup holder.....               | -- |
| (11) Glove box.....                | -- |
| (12) Operator's manual holder..... | -- |
| (13) 12V accessory plug.....       | 21 |
| (14) Speed control pedal.....      | 17 |
| (15) Brake pedal.....              | 16 |

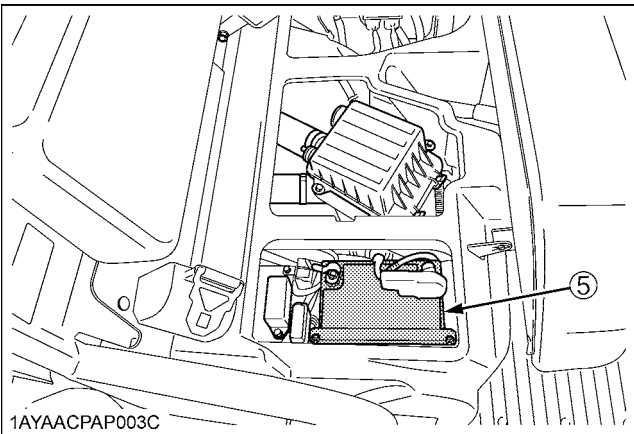
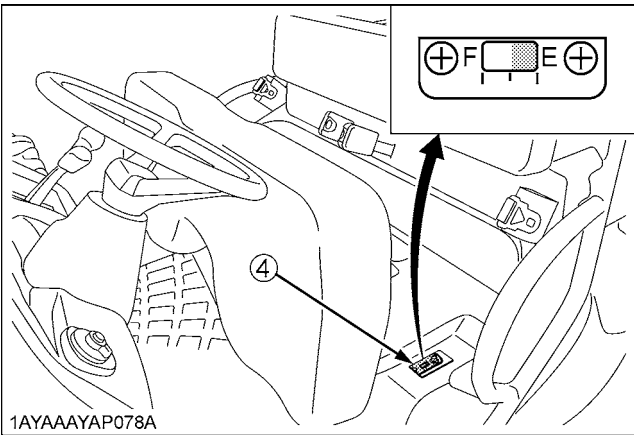
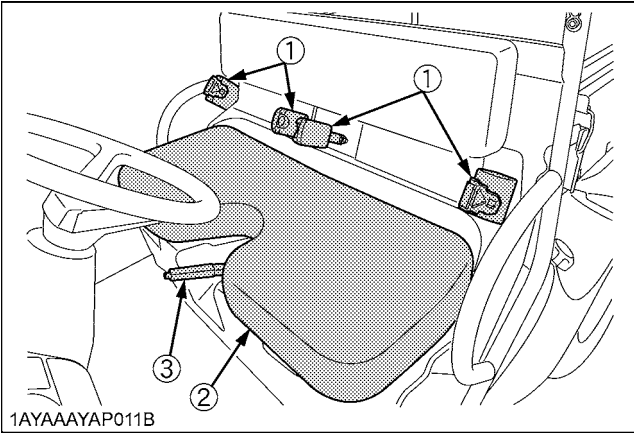

ILLUSTRATED CONTENTS

|                              |    |
|------------------------------|----|
| (1) Seat belts.....          | 14 |
| (2) Seat.....                | 38 |
| (3) Parking brake lever..... | 20 |
| (4) Fuel gauge.....          | 19 |
| (5) Battery.....             | -- |

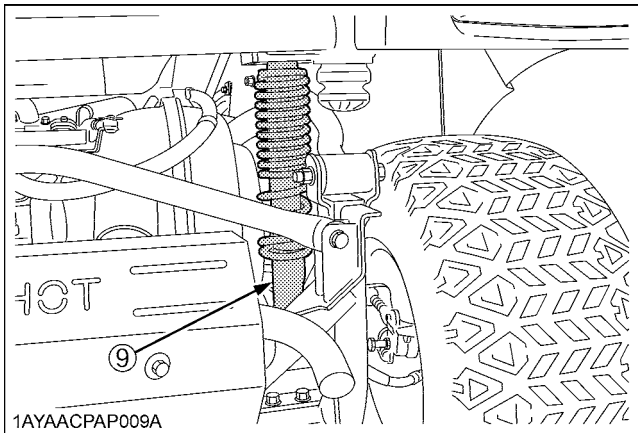
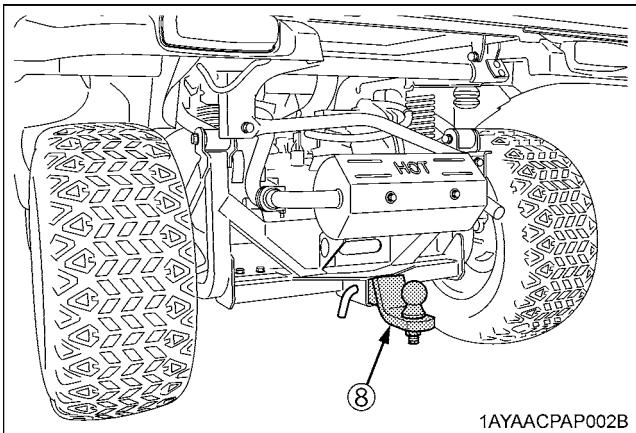
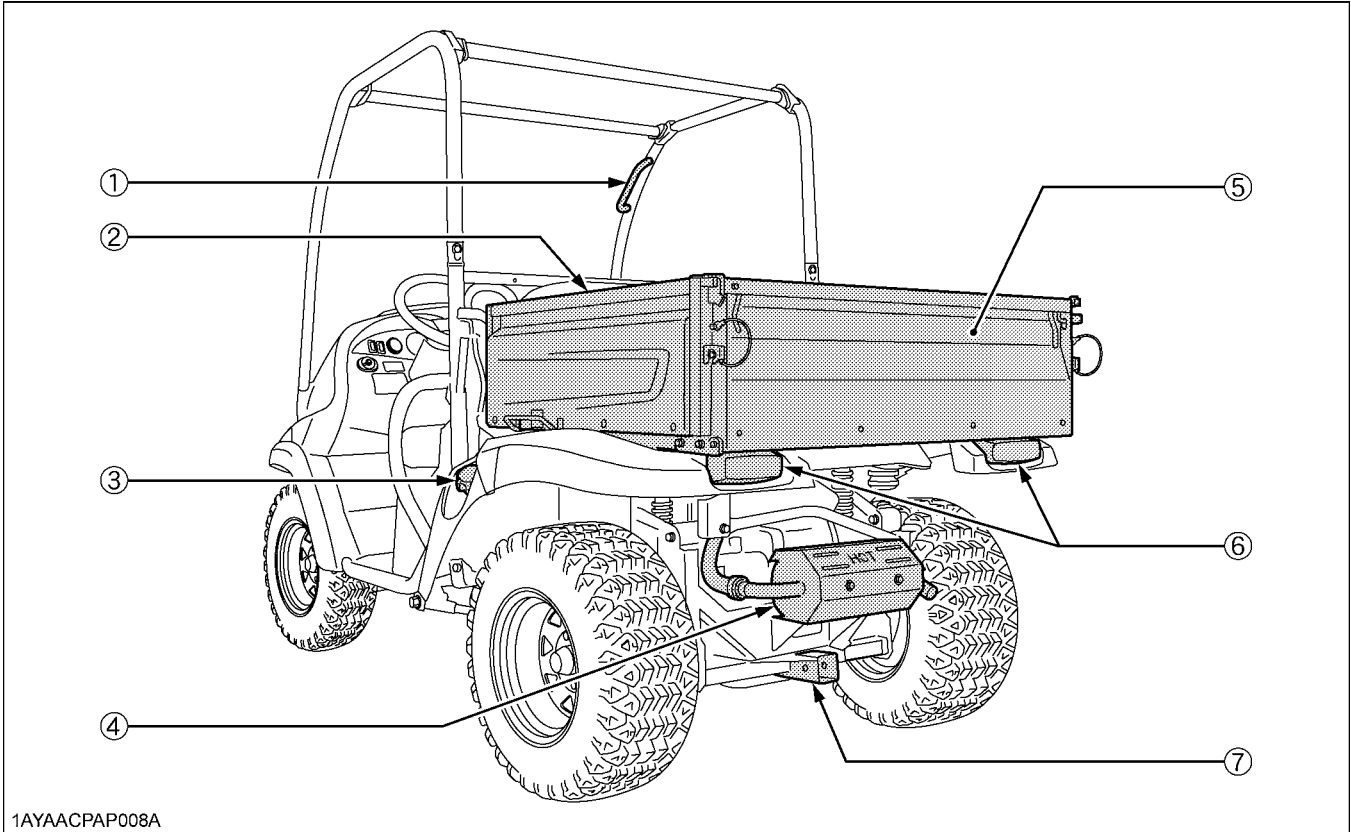

ILLUSTRATED CONTENTS

|                        |    |
|------------------------|----|
| (1) Handgrip.....      | -- |
| (2) Cargo bed.....     | 26 |
| (3) Fuel tank cap..... | -- |
| (4) Muffler.....       | -- |

ILLUSTRATED CONTENTS

|   |    |
|---|----|
| (5) Tailgate.....                         | 27 |
| (6) Tail lamp.....                        | -- |
| (7) Rear trailer hitch bracket.....       | 31 |
| (8) Rear trailer hitch (if equipped)..... | 31 |
| (9) Rear shock absorber.....              | 30 |

# PRE-OPERATION CHECK

## DAILY CHECK

To prevent trouble from occurring, it is important to know the condition of the vehicle well. Check it before starting.



### CAUTION

To avoid personal injury:

- **Be sure to check and service the vehicle on a level surface with the engine shut off and the parking brake "ON" and implement lowered to the ground if equipped.**

#### Check item

- Walk around inspection
- Check engine oil level
- Check transmission fluid level
- Check brake fluid level
- Check brake
- Check parking brake
- Check indicators, gauges and meters
- Check lights
- Check seat belt and ROPS
- Check front and drive joint boots
- Check tire inflation pressure
- Refuel

(See "DAILY CHECK" in "PERIODIC SERVICE" section.)

- Care of danger, warning and caution labels  
(See "DANGER, WARNING AND CAUTION LABELS" in "SAFE OPERATION" section.)

# OPERATING THE ENGINE



## CAUTION

To avoid personal injury

- Read "SAFE OPERATION" in the front of this manual.
- Read the danger, warning and caution labels located on the vehicle.
- To avoid the danger of exhaust fume poisoning, do not operate the engine in a closed building without proper ventilation.
- Never start engine while standing on ground. Start engine only at the operator's seat.
- Make it a rule to set the range gear shift lever to the "NEUTRAL" position.

## IMPORTANT :

- Do not use starting fluid to aid engine starting.
- To protect the battery and the starter, make sure that the starter is not continuously turned for more than 10 seconds.

If the engine does not start, allow 60-second cool down period between start attempts.

## STARTING THE ENGINE

1. Make sure the parking brake is applied.

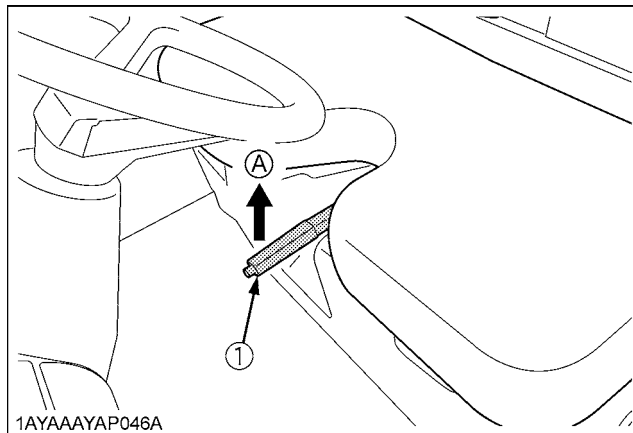

(1) Parking brake lever

(A) Pull to "PARK"

## NOTE :

- The brake indicator light comes on while parking brake is applied and goes off when it is released.

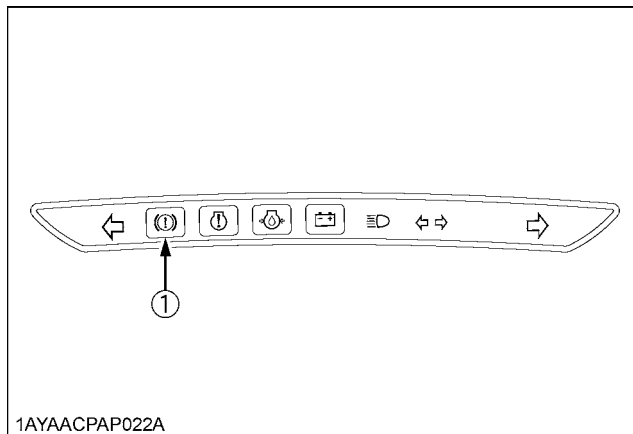

(1) Brake indicator light

**2. Set the range gear shift lever to the "NEUTRAL" position.**

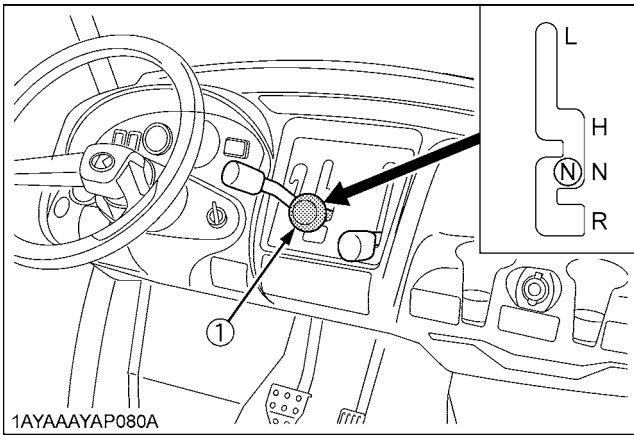

(1) Range gear shift lever  
 (L) LOW Range  
 (H) HIGH Range  
 (N) "NEUTRAL" POSITION  
 (R) "REVERSE"

**3. Insert the key into the key switch and turn it "ON".**

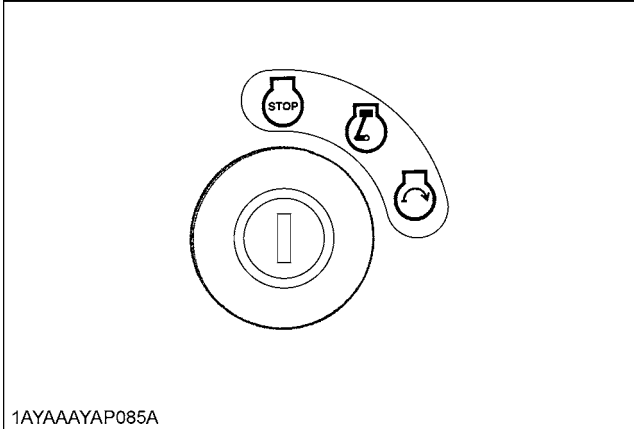

(⏻) "OFF" (Engine-Stop)      (🔑) "START" (Engine-Start)  
 (⏻) "ON" (Engine-Run)

**◆ Check Easy Checker(TM) Lamps:**

1. When the key is turned "ON", lamps(2)(3)(4) should come on. If trouble should occur at any location while the engine is running, the warning lamp corresponding to that location comes on.
2. The brake indicator light(1) comes on.
  - (1) While brake is applied and goes off when it is released.
  - (2) When the brake fluid is below the "MIN" mark. (Add the brake fluid to the "MAX" mark.) (See "Checking Brake Fluid Level" in "DAILY CHECK" in "PERIODIC SERVICE" section.)

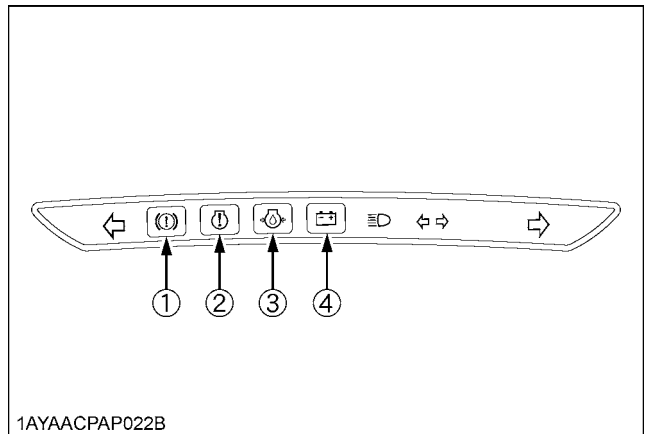

(1) Brake indicator light  
 (2) Engine diagnostic light  
 (3) Engine oil pressure light  
 (4) Electrical charge light

**IMPORTANT :**

- Daily checks with the Easy Checker(TM) only, are not sufficient. Never fail to conduct daily checks carefully by referring to "DAILY CHECK" in "PERIODIC SERVICE" section.

**NOTE :**

- For further details of Easy Checker(TM), see "Easy Checker(TM)" in "CHECK DURING DRIVING" in "OPERATING THE VEHICLE" section.

**4. Turn the key to the "START" position and release when the engine starts.**

**IMPORTANT :**

- As safety function, the engine will not start unless the range gear shift lever is in the "NEUTRAL" position.

### ■ Cold Weather Starting

When the ambient temperature is below 0 °C (32 °F), the engine is very cold. If the engine fails to start after 10 seconds, turn off the key for 30 seconds. Then repeat steps 3 and 4. To protect the battery and the starter, make sure that the starter is not continuously turned for more than 10 seconds.

If it is difficult to start the engine, step on the speed control pedal slightly.

It is likely to occur engine stalling without its warming up. In this case re-start engine with depressing speed control pedal approximately 1/4.

### STOPPING THE ENGINE

1. After slowing the engine to idle, turn the key to "OFF".
2. Remove the key.

### WARMING UP



#### CAUTION

To avoid personal injury:

- Be sure to set the parking brake during warm-up.
- Be sure to set the range shift lever to the "NEUTRAL" position.

For 5 minutes after engine start-up, allow the engine to warm up without applying any load. This is to allow oil to reach every engine part. If load should be applied to the engine without this warm-up period, trouble such as seizure, breakage or premature wear may develop.

## JUMP STARTING



### CAUTION

To avoid personal injury:

- Battery gases can explode. Keep cigarettes, sparks, and flames away from battery.
- If vehicle battery is frozen, do not jump start engine.
- Do not connect other end of negative jumper cable to negative terminal of vehicle battery.
- The parts such as the muffler may be hot. Be careful not to get burned in connecting jumper cables.

When jump starting engine, follow the instructions below to safely start the engine.

1. Bring helper vehicle with a battery of the same voltage as disabled vehicle within easy cable reach. "THE VEHICLES MUST NOT TOUCH".
2. Engage the parking brake of both vehicles and put the shift lever in neutral. Shut the engine off.
3. Put on safety goggles and rubber gloves.
4. Ensure the vent caps are securely in place. (if equipped)
5. Attach the red clamp to the positive (red, (+) or pos.) terminal of the dead battery and clamp the other end of the same cable to the positive (red, (+) or pos.) terminal of the helper battery.
6. Clamp the other cable to the negative (black, (-) or neg.) terminal of the helper battery.
7. Clamp the other end to the engine block or frame of the disabled vehicle as far from the dead battery as possible.
8. Start the helper vehicle and let its engine run for a few moments. Start the disabled vehicle.
9. Disconnect the jumper cables in the exact reverse order of attachment. (Steps 7, 6 and 5).

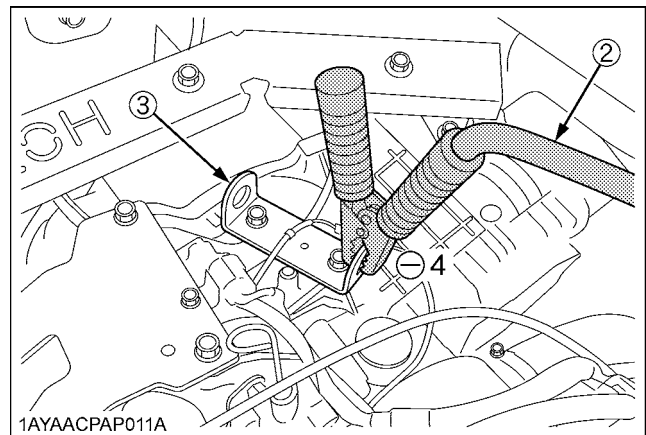
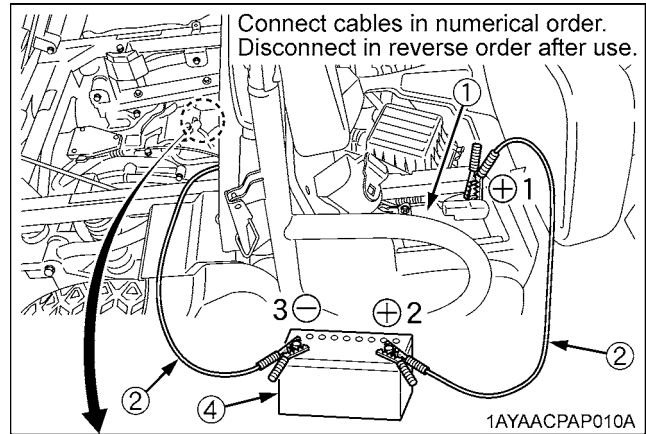

- (1) Dead battery
- (2) Jumper cables
- (3) Engine block or frame
- (4) Helper battery

### IMPORTANT :

- This vehicle has a 12 volt negative (-) ground starting system.
- Use only same voltage for jump starting.
- Use of a higher voltage source could result in severe damage to vehicle's electrical system.  
Use only matching voltage source when "Jump starting" a low or dead battery.



# OPERATING THE VEHICLE

## OPERATING NEW VEHICLE

How a new vehicle is handled and maintained determines the life of the vehicle.

A new vehicle just off the factory production line has been, of course, tested, but the various parts are not accustomed to each other, so care should be taken to operate the vehicle for the first 50 hours at a slower speed and avoid excessive work or operation until the various parts become "broken-in." The manner in which the vehicle is handled during the "breaking-in" period greatly affects the life of your vehicle. Therefore, to obtain the maximum performance and the longest life of the vehicle, it is very important to properly break-in your vehicle. In handling a new vehicle, the following precautions should be observed.

### ■ Do not Operate the Vehicle at Full Speed for the First 50 Hours

- Do not start quickly nor apply the brakes suddenly.
  - In winter, operate the vehicle after fully warming up the engine.
  - Do not run the engine at speeds faster than necessary.
  - On rough roads, slow down to suitable speeds.
- Do not operate the vehicle at fast speed. The above precautions are not limited only to new vehicles, but to all vehicles. But it should be especially observed in the case of new vehicles.

### ■ Changing Lubricating Oil for New Vehicles

The lubricating oil is especially important in the case of a new vehicle. The various parts are not "broken-in" and are not accustomed to each other. Small pieces of metal grit may develop during the operation of the vehicle; and this may wear out or damage the parts. Therefore, care should be taken to change the lubricating oil a little earlier than would ordinarily be required. For further details of change interval hours, see "MAINTENANCE" section.

## STARTING

### 1. Fasten the seat belt.

#### ■ Seat Belt



### WARNING

To avoid personal injury:

- Seat belts reduce injury. Always wear your seat belts. The lap-style seat belts may not provide adequate protection for small children. Special care is recommended when carrying a child passenger.



### CAUTION

To avoid personal injury:

- Always use the seat belts when operating and riding in the vehicle.

Adjust the seat belts for proper fit and connect the buckle. This seat belt is an auto-locking retractable type.

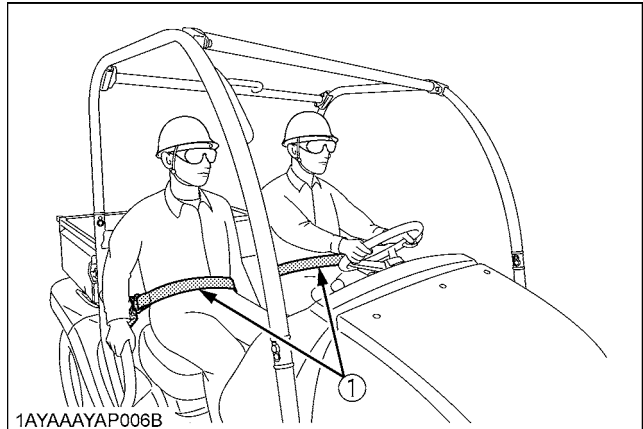

(1) Seat belt

## 2. Selecting light switch position.

### ■ Head Light Switch

The head light switch is operative when the key switch is in the "ON" position.

Turn on the key switch and turn the head light switch to the "ON" position.

Turn the head light switch to the "OFF" position to turn off the head light.

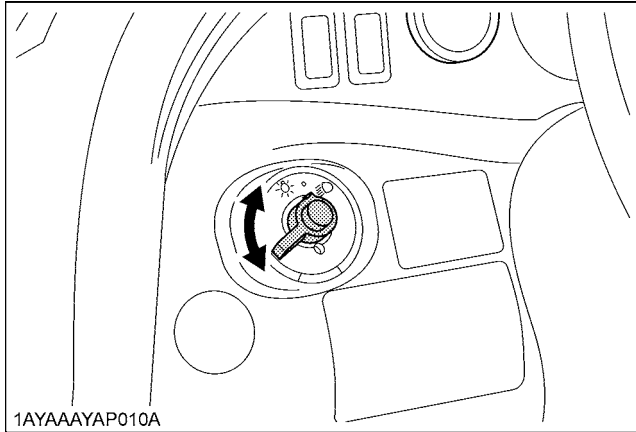

(1) Head light switch

☰○ Head lights "ON"  
○ Head lights "OFF"

### ■ Horn Button

The horn switch is operative when the key switch is in either the "ON" or "OFF" position.

The horn will sound when the horn button is pressed.

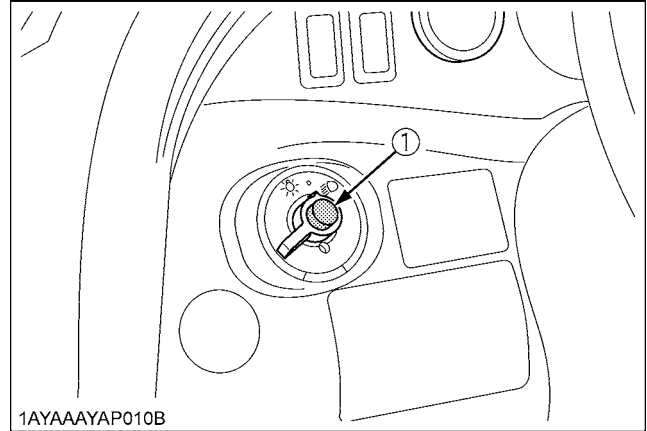

(1) Horn button

### NOTE :

- Turning the head light switch to the "ON" position causes the following lamps to light simultaneously.
  - (1) Tail lights (lamps at the rear portions of the vehicle)
- Do not allow the headlights to remain on when idling.

### 3. Checking the brake pedal.

#### ■ Brake Pedal



#### CAUTION

To avoid personal injury:

- If the operator suddenly brakes, an accident may occur due to loss of control or the shifting forward of heavy loads.
- When driving on icy, wet or loose surface, make sure the vehicle is correctly ballasted to avoid skidding and loss of steering control. Operate at reduced speed.

The brake pedal is the left pedal on the foot board. Depress the pedal to slow or stop the vehicle.

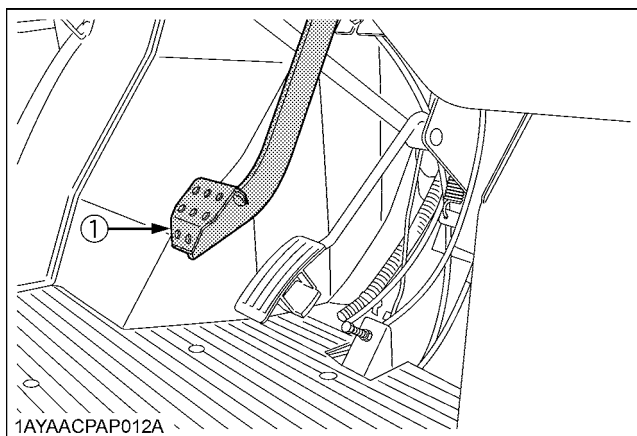

(1) Brake pedal

### 4. Selecting the travel speed.

#### ■ Range Gear Shift Lever



#### CAUTION

To avoid personal injury:

- Avoid changing range gear shift lever when ascending or descending a slope.
- Before ascending or descending a slope, shift to the "L" range to control the vehicle speed.
- If you shift gears while ascending or descending a slope, be prepared to use the brake to maintain control.
- Operate in reverse at slow speeds to maintain control.

1. The range gear shift lever can only be shifted when vehicle is completely stopped and the speed control pedal is in the "NEUTRAL" position.
2. To avoid transmission and shift linkage damage, completely stop the vehicle using the brake pedal before shifting gears.  
Shift the gears with the engine running at idling speed.
3. Select proper gear and engine speed depending on the type of job.
4. Before dismounting vehicle, shift the range gear shift lever to the "NEUTRAL" position and apply parking brake.

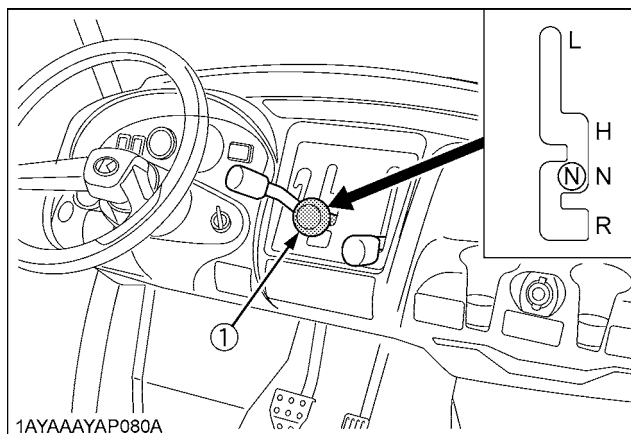

(1) Range gear shift lever

(L) LOW Range  
(H) HIGH Range  
(N) "NEUTRAL" POSITION  
(R) "REVERSE"

**NOTE :**

- Do not force the range gear shift lever. If it is difficult to shift the lever into "L", or "H" on slopes, be sure to apply the parking brake before starting the procedure.
  - (1) Slightly depress the speed control pedal to rotate the gears inside of transmission.
  - (2) Release the speed control pedal to the "NEUTRAL" position.
- An accident may occur with erratic shifting operation.
- Improper range gear shift lever position will cause the vehicle to momentarily coast on slopes.

**4WD Lever**



**CAUTION**

To avoid personal injury:

- Do not engage the front wheel drive when traveling at road speed.
- When driving on icy, wet or loose surfaces, make sure the vehicle is correctly ballasted to avoid skidding and loss of steering control. Operate at reduced speed and engage front wheel drive.
- An accident may occur if the vehicle is suddenly braked, such as by heavy towed loads shifting forward causing loss of control.
- The braking characteristics are different between two and four wheel drive. Be aware of the difference and use carefully.

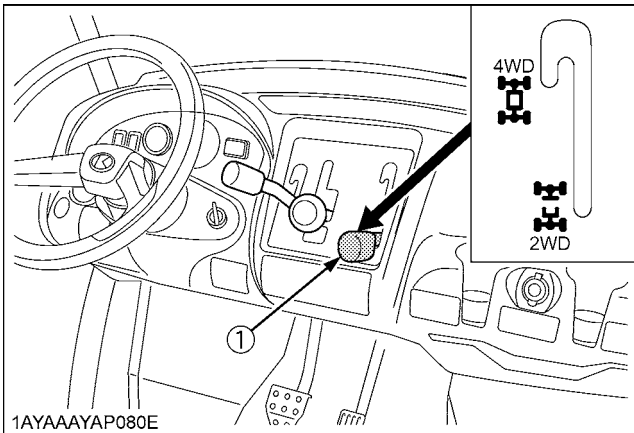

(1) 4WD lever

"4WD"  
 "2WD"

**IMPORTANT :**

- Use the lever to engage the front wheels with the vehicle stopped. Shift the lever to "4WD" to engage the front wheel drive.
- Tires will wear quickly if front wheel drive is engaged on paved roads.
- If the 4WD lever is difficult to shift to "2WD", stop the vehicle, turn the steering wheel in both directions and then move the lever.

**◆ Front wheel drive is effective for the following jobs:**

1. When greater pulling force is needed, such as working in a wet field, when pulling a trailer, or when working with a front-end blade.
2. When working in sandy soil.
3. When working on snow-covered terrains.

**5. Unlock the parking brake and start slowly.**

**■ Parking Brake Lever**

To release the parking brake, depress the brake pedal, push release button and push down parking brake lever. Make sure that indicator in the Easy Checker(TM) goes off.

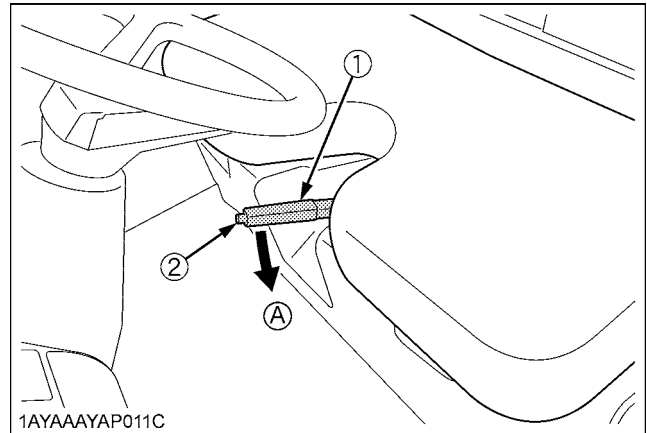

(1) Parking brake lever

(A) "RELEASE"

(2) Release button

**■ Speed Control Pedal**

Use the speed control pedal when traveling. Push down on it for higher speed.

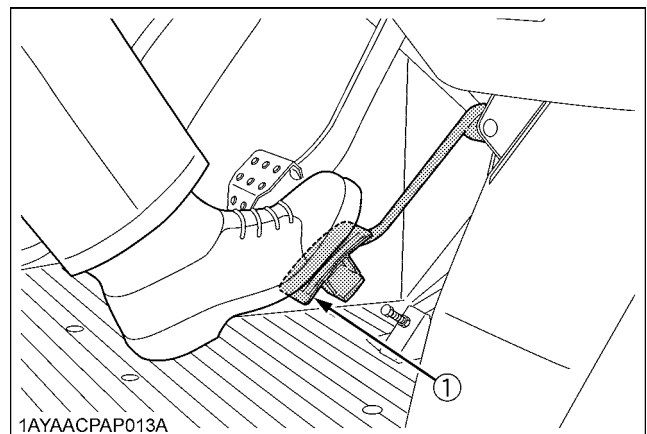

(1) Speed control pedal

## STOPPING

### ■ Stopping

1. Release the speed control pedal.
2. Step on the brake pedal.
3. After the vehicle has stopped, put the range gear shift lever in neutral, and apply the parking brake.

## CHECK DURING DRIVING

### ■ Immediately Stop the Engine if:

- The engine suddenly slows down or accelerates,
  - Unusual noises are suddenly heard,
  - Exhaust fumes suddenly become very dark,
- While driving, check the following items to see that all the parts are functioning normally.

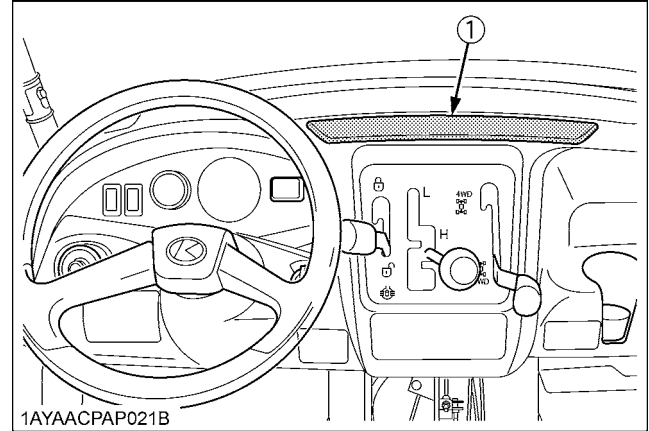

(1) Easy Checker(TM)

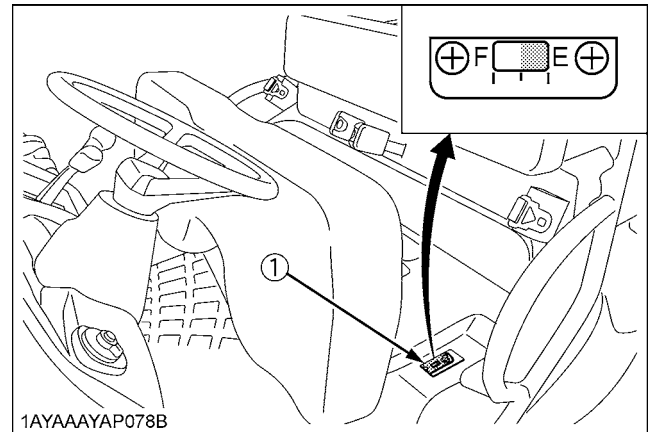

(1) Fuel gauge

## ■ Easy Checker(TM)

If the warning lamps in the Easy Checker(TM) come on during operation, immediately stop the engine, and find the cause as shown below.

Never operate the vehicle with an Easy Checker(TM) lamp on.

### (!) Brake indication light

The warning lamp in the Easy Checker(TM) comes on if the parking brake is applied.

If the lamp is on during operation, release the parking brake lever immediately.

If the brake fluid goes below the prescribed level, the warning lamp in the Easy Checker(TM) will come on.

If this should happen during operation, check to see that there is no oil leak in the brake system, and then add oil.

(See "Checking Brake Fluid Level" in "DAILY CHECK" in "PERIODIC SERVICE" section.)

### (D) Engine diagnostic light

If sensors malfunction, the Easy Checker(TM) will come on. If the light is active, stop the vehicle and shut off the engine. If the light is active after restart, consult your local KUBOTA Dealer.

### (O) Engine oil pressure light

If the oil pressure in the engine goes below the prescribed level, the warning lamp in the Easy Checker(TM) will come on.

If this should happen during operation, and it does not go off when the engine is accelerated, check the level of engine oil.

(See "Checking Engine Oil Level" in "DAILY CHECK" in "PERIODIC SERVICE" section.)

### (B) Electrical charge light

If the alternator is not charging the battery, the Easy Checker(TM) will come on.

If this should happen during operation, check the electrical charging system or consult your local KUBOTA Dealer.

## ■ Fuel Gauge

The fuel gauge indicates the fuel level.

Be careful not to empty the fuel tank. Otherwise air may enter the fuel system.

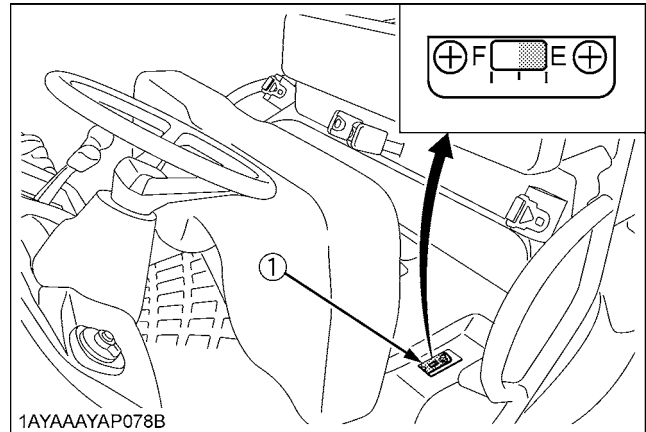

(1) Fuel gauge

(F) "FULL"

(E) "EMPTY"

### IMPORTANT :

- Do not refuel over "F". Fill the tank only to the bottom of the filler neck in the fuel tank.

## Hourmeter

The hourmeter indicates in 5 digits the hours the vehicle has been used; the last digit indicates 1/10 of an hour.

Use the hourmeter to see if your vehicle has reached the recommended service intervals, and do your vehicle maintenance yourself or have its maintenance done by your local KUBOTA Dealer as necessary.

(See "SERVICE INTERVALS" in "MAINTENANCE" section.)

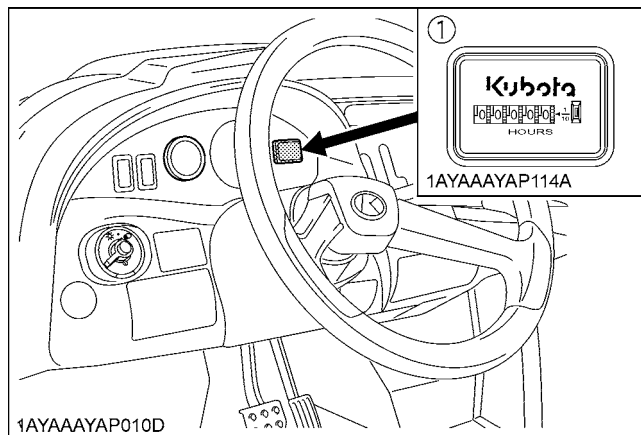

(1) Hourmeter

## PARKING

### Parking Brake Lever



### CAUTION

To avoid personal injury:

#### BEFORE DISMOUNTING VEHICLE

- ALWAYS APPLY THE PARKING BRAKE AND LOWER ALL IMPLEMENTS TO THE GROUND. Leaving transmission in gear with the engine stopped will not prevent from rolling.
- STOP THE ENGINE AND REMOVE THE KEY.

1. Stop the vehicle on a level surface.
2. To apply the parking brake, depress the brake pedal and pull the parking brake lever to park.
3. To release the parking brake, push the release button and push down the parking brake lever. When the parking brake is released, the brake indicator light in the Easy Checker(TM) goes off.

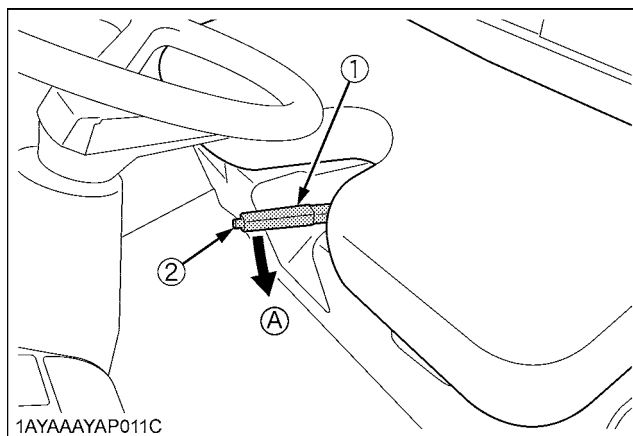

(1) Parking brake lever

(A) "RELEASE"

(2) Release button

### IMPORTANT :

- If the vehicle is operated with the parking brake applied, the parking brake will be damaged.

## ACCESSORY

### ■ 12V Electric Outlet

The 12 volt receptacle is located on the front-panel. An auxiliary light or other devices may be connected to this connector.

- ◆ This outlet is activated when the key switch is in either the "ON" or "OFF" position.

When the plug is not used, pull it out. Be careful that leaving the plug inserted causes the battery to run out.

- ◆ Do not connect a light or other device that draws more than 120 watts to this connector, or the battery may discharge very rapidly or the outlet may fail.

#### IMPORTANT :

- Do not use as a cigarette lighter.
- Do not use when wet.

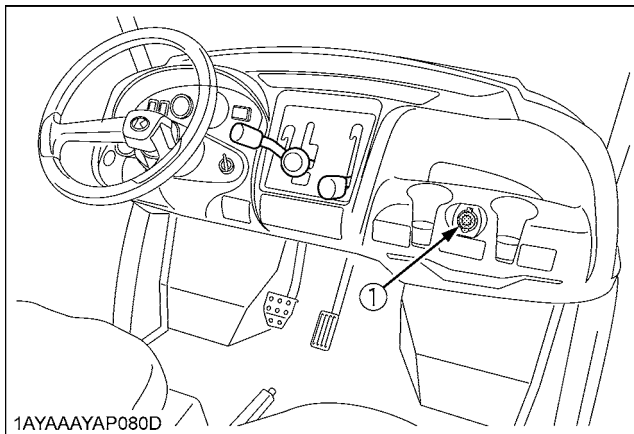

(1) 12V electric outlet

## OPERATING TECHNIQUES

### ■ Differential Lock



#### WARNING

To avoid personal injury due to loss of steering control:

- Do not operate the vehicle at high speed with differential lock engaged.
- Do not attempt to turn with the differential lock engaged.
- Be sure to release the differential lock before making a turn in field conditions.

If one of the rear wheels should slip, shift the differential lock lever to the "ENGAGE" position. Both wheels will then turn together, reducing slippage.

Differential lock is maintained while shifting the differential lock lever to the "ENGAGE" position.

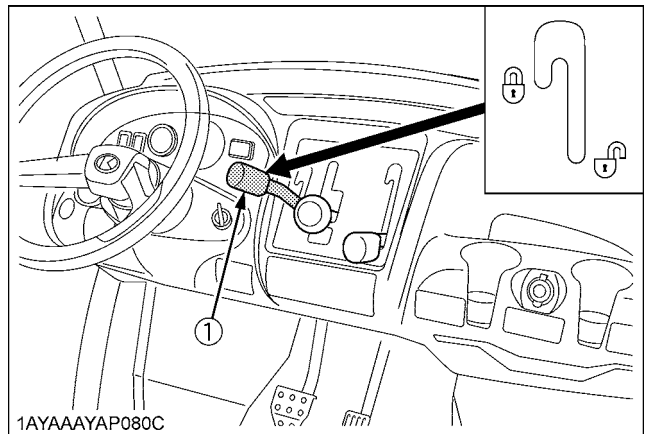

(1) Differential lock lever

🔒 "ENGAGE"

🔓 "DISENGAGE"

#### IMPORTANT :

- When using the differential lock, always slow the engine down.
- To prevent damage to power train, do not engage differential lock when one wheel is spinning and the other is completely stopped.
- If the differential lock cannot be released, stop the vehicle, turn the steering wheel alternately.



**■ Unfamiliar Terrain****CAUTION**

To avoid personal injury:

- Be sure to check for hidden obstacles or hazards before driving in a new area.
- Keep your speed down until you know the area well.
- Use existing trails and stay away from hazardous areas such as steep, rocky slopes or swamps.
- Be cautious when visibility is limited, as you may not be able to see obstacles in your path.

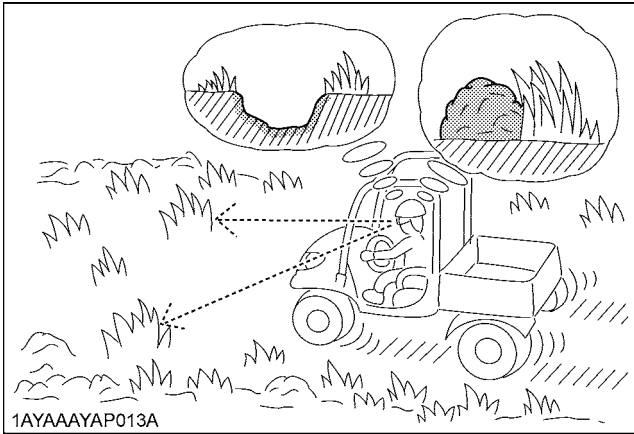
**■ Driving in Reverse****CAUTION**

To avoid personal injury:

- Turn around, look down and behind you before backing up to be sure there are no obstacles or people in your way.
- Depress speed control pedal gradually and back up cautiously.
- To stop while driving in reverse take your foot off the speed control pedal and gradually apply the brake.
- Do not suddenly engage the brake.

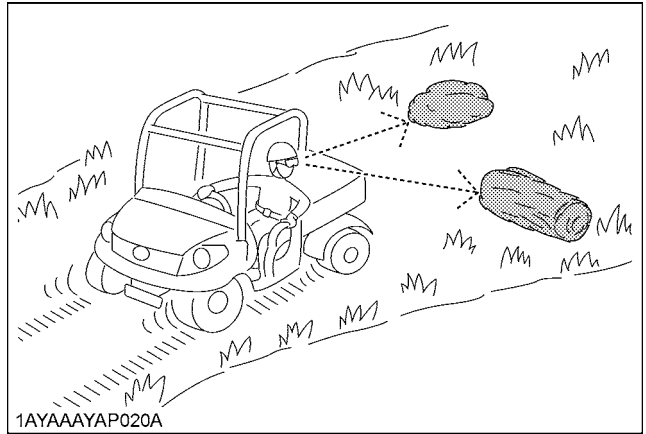

## ■ Driving in "4WD"



### CAUTION

To avoid personal injury:

- Do not drive in "4WD" on paved surfaces.

For the maximum traction, shift the range gear shift lever into low range and use "4WD" on steep slopes or when stuck in the mud, with differential locked if necessary.

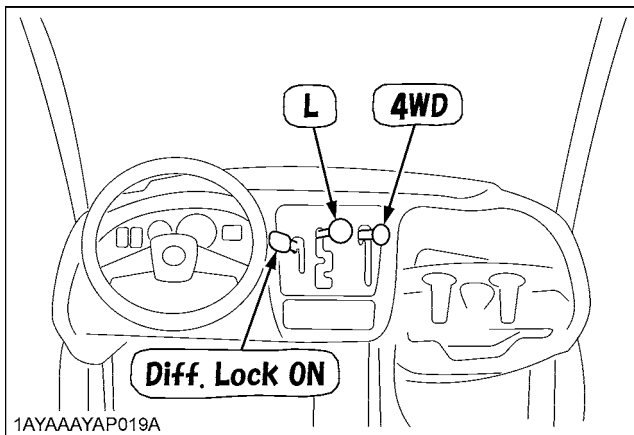
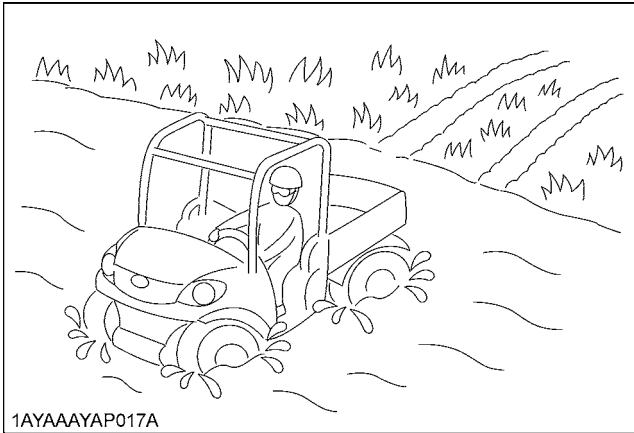

## ■ Turning the Vehicle



### WARNING

To avoid personal injury:

- Reduce vehicle speed before entering the turn and maintain an even speed through the turn.
- Do not make sharp turns in order to avoid loss of control or tipping.

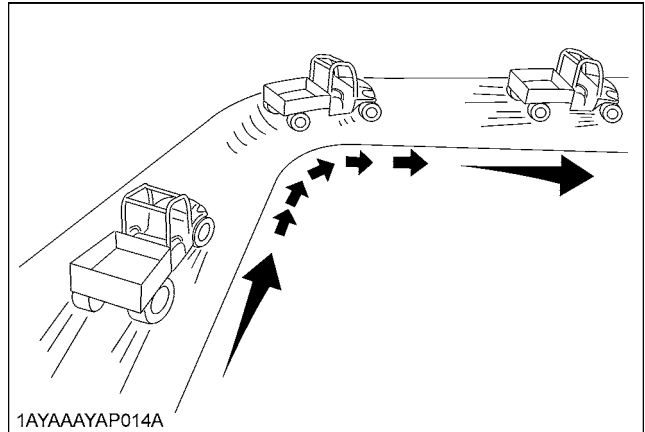

■ Hills

**! WARNING**

To avoid personal injury:

- Do not turn sideways on a hill, or the vehicle may roll over.
- Always go straight up hill or down hill.
- Slow down until you can get a clean view of the other side at the crest of a hill.
- If the engine stalls on a steep slope, roll slowly straight down, using the brake.
- Stop and look for obstacles before descending a hill.

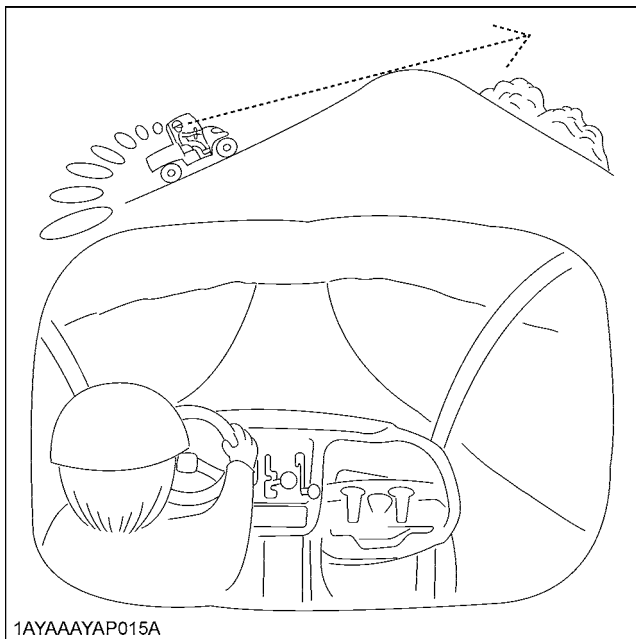

1AYAAAYAP015A

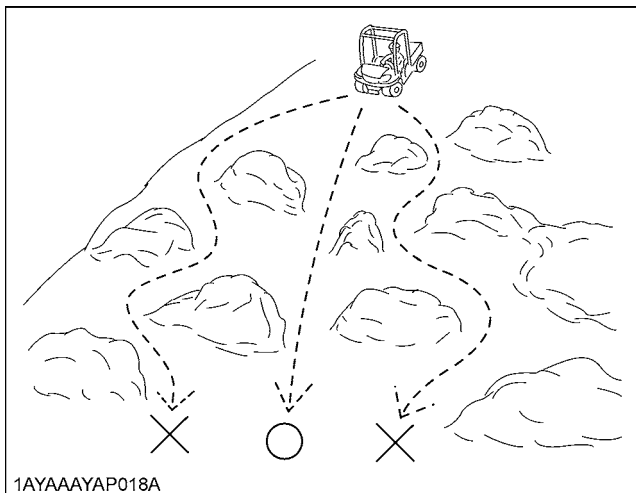

1AYAAAYAP018A

■ Traversing Hillsides

**! WARNING**

To avoid personal injury:

- Reduce vehicles speed to prevent tipping or loss of control.
- Do not traverse hillsides that are slippery or covered with rocks or obstacles which may cause you to tip over.

■ Sliding and Skidding

**! WARNING**

To avoid personal injury:

- Drive slowly and carefully when you are unsure or unprepared for the surface.
- Do not apply heavy braking force or accelerate when skidding to prevent loss of control.
- Use 4WD and maintain low speeds on areas covered with clay, mud, ice or snow to prevent uncontrolled skidding.

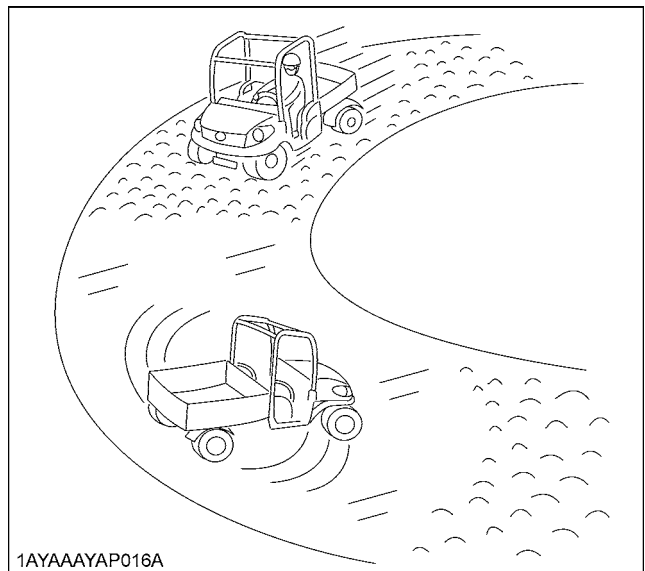

1AYAAAYAP016A

■ Driving through Water

**WARNING**

To avoid personal injury:

- Do not drive through water whenever it is possible.
- Drive slowly across shallow water and choose a location to enter and exit the water where the banks are not too steep or slippery.
- Check before entering for rocks, holes or other obstacles that may cause overturn, get stuck or submerged.
- Never operate the vehicle in fast flowing water or in excess of 6 inches (152 mm) in depth. Tires may float, making it difficult to maintain control, and also may cause starter trouble.
- Wet brakes may reduce the stopping ability of the vehicle. After operating in water, always apply the brakes to dry them out.
- The brake that gets wet may wear out faster. Check for brake wear more frequently if operating in water often.

**IMPORTANT :**

- Operate the vehicle in water not deeper than 6 inches (152 mm) as the engine cooling fin could be clogged with mud and the electrical parts could be damaged. Muddy water could enter into the engine cooling air inlet for the air-cooled engine.
- After operating the vehicle in water, remove the rubber plug from the CVT cover, check for accumulated water and drain it.

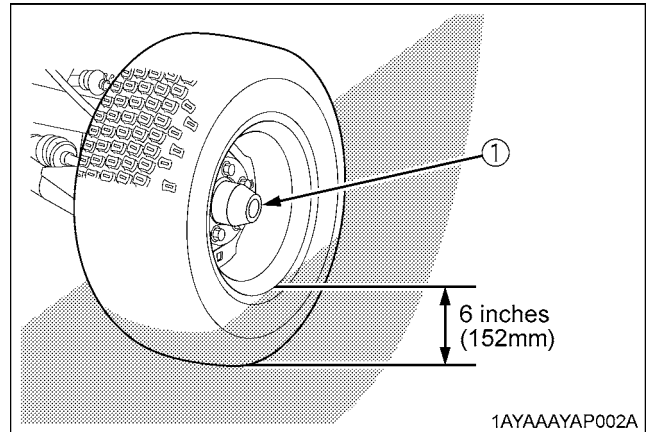
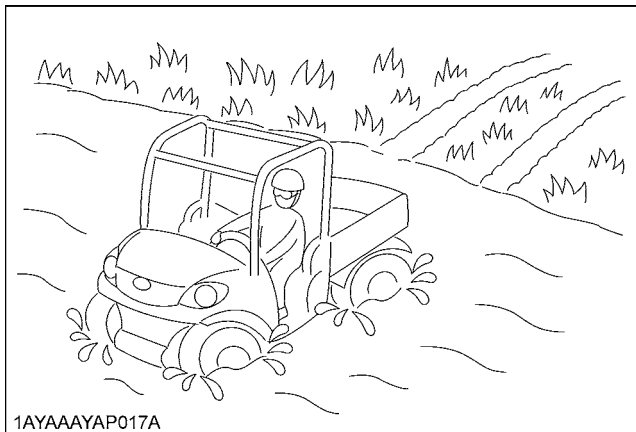

(1) Axle cap

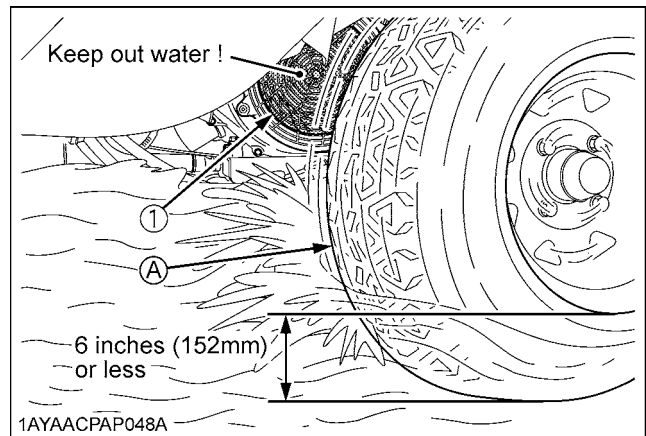

(1) Engine cooling air inlet (A) Left rear tire

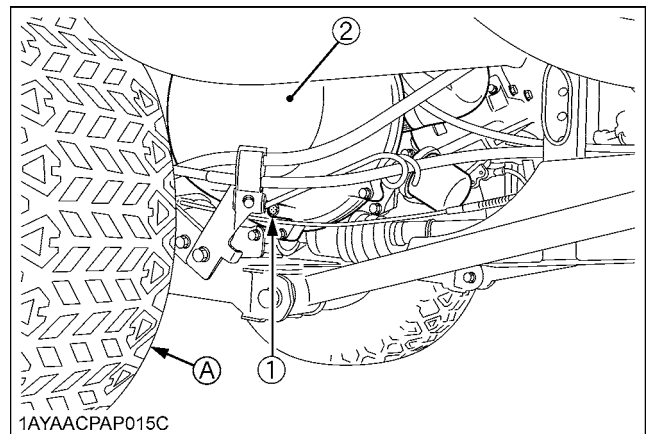

(1) Rubber plug (2) CVT cover (A) Right rear tire

# CARGO BED

## CARGO BED

### General Caution



### WARNING

To avoid personal injury:

- Never carry passengers in the cargo bed. They can be tossed about or even thrown off causing serious injury or death.
- Never raise the cargo bed when it is loaded.
- Driving with the cargo bed tilted may be hazardous.  
Always lower the bed and latch the bed before driving.
- Be careful not to put any part of your body, such as hands or arms, between the bed and vehicle.
- Drive slowly when it is loaded.









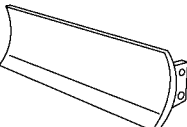

### CAUTION

To avoid personal injury:

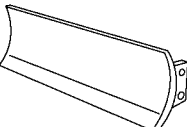
- Do not raise the cargo bed while the engine is running above low idle.

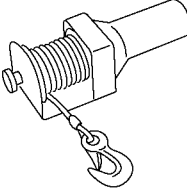
### Max. Cargo Load

|   | Operator   | Passenger  | Implement   | Max. Cargo Load      |
|---|--|--|---|----------------------|
| ROPS type<br>  | <br>95 kg (209 lbs) | ---  | W: weight<br> | 200 kg (441 lbs) - W |
|   | <br>95 kg (209 lbs) | <br>95 kg (209 lbs) | Blade<br>     | 200 kg (441 lbs) - W |
| CAB type<br><br>104 kg (229 lbs)<br><small>1AYAACPAP058A</small> | <br>95 kg (209 lbs) | ---  | Winch<br>     | 200 kg (441 lbs) - W |
|   | <br>95 kg (209 lbs) | <br>95 kg (209 lbs) |   | 186 kg (410 lbs) - W |

### IMPORTANT :

- Maximum Cargo Load (MCL) capacity is 200 kg (441 lbs).
- Never carry loads exceeding the Permissible Cargo Load (PCL).

### NOTE :

- Max. Cargo load should not exceed "200 kg (441 lbs.)" or "CL".  
 CL = PC - (operator + passenger + opt. + acc. + cabin) weight  
 (CL: Cargo Load / PC: Payload Capacity / opt.: option / acc.: accessory)

### [Payload capacity]

|                            |            |
|----------------------------|------------|
| Payload capacity kg (lbs.) | 480 (1058) |
|----------------------------|------------|

## ■ Cargo Bed Tailgate



### CAUTION

To avoid personal injury:

- Do not apply a load to the tailgate while the tailgate is open, or the wire loop may break.
- Do not place fingers or hands between the tailgate and the arm (latch) when closing, or fingers or hands may be pinched.

For loading and unloading, the tailgate of the cargo bed can be opened.

The tailgate is held level to the cargo bed floor with wire loops.

Do not move the vehicle with the tailgate fully lowered.

In a fully lowered position, the tailgate may obstruct the vehicle tail lamps and damage them by swinging motion.

1. Raise the arms (latch) at each end of the tailgate and open the tailgate.
2. Close the tailgate by lifting it and pushing it firmly closed. Push the arms (latch) down to make sure the latches stay securely closed.

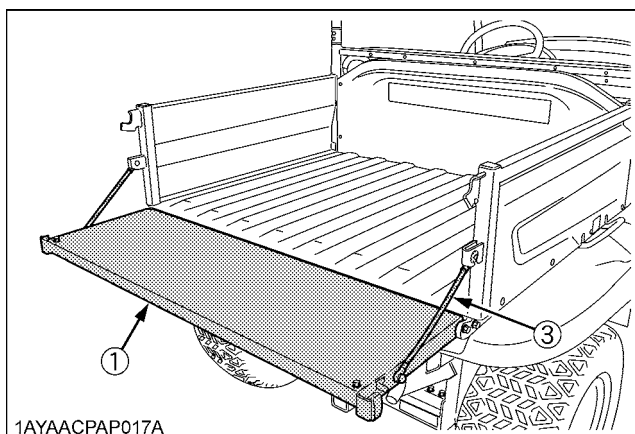
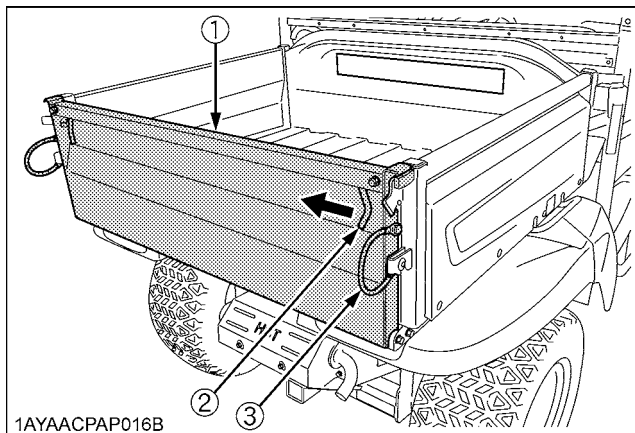

- (1) Tailgate  
 (2) Arm (latch)  
 (3) Wire loop

### IMPORTANT :

- TO AVOID TAILGATE DAMAGE:  
 Remove the rear trailer hitch when wire loop is removed and cargo bed is raised.

### ■ Raising and Lowering the Cargo Bed



#### CAUTION

To avoid personal injury;

- Make sure the vehicle is on a firm, level surface and the parking brake is applied before raising the cargo bed and securing the cargo bed in the raised position.
- A loaded cargo bed can be very heavy. Never raise the cargo bed when it is loaded. Unload the cargo bed before raising it by hand.

1. Park the vehicle on a flat surface.
2. Empty the cargo bed by hand.
3. Release the latches on both sides and then raise the cargo bed with the hand grip.

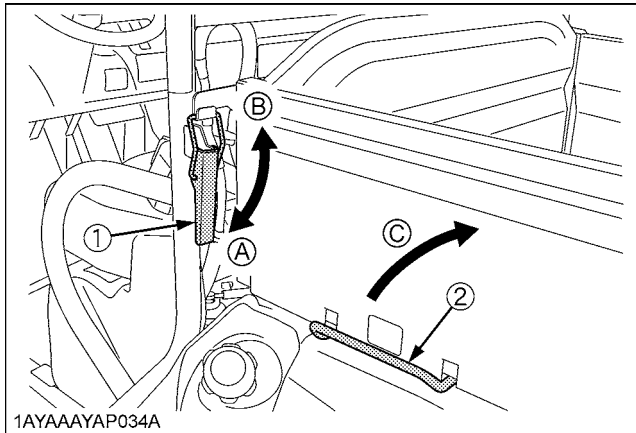

(1) Latch

(2) Hand grip

(A) "LOCK"

(B) "RELEASE"

(C) "RAISE"

4. Push the safety support into the latch slot to lock when the cargo is fully raised.

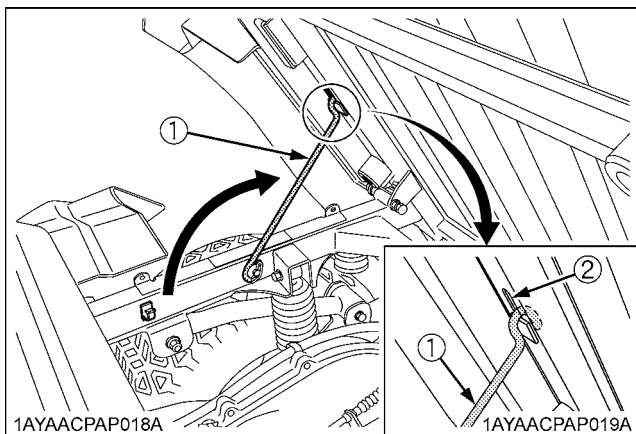

(1) Safety support

(2) Latch slot

5. To lower the cargo bed, raise the cargo bed slightly using the handgrip.

6. Release the safety support from the latch slot by pulling up on the middle of the support.
7. Put the safety support into the support holder.

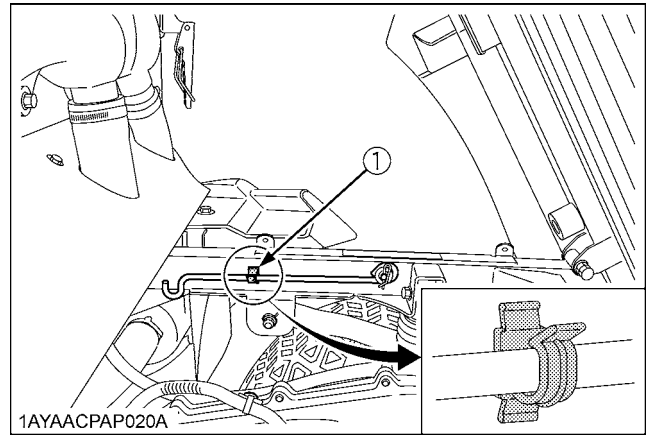

(1) Support holder

8. Slowly lower the cargo bed onto the frame and set the latches on both sides.

# TIRES AND WHEELS

## TIRES



### WARNING

To avoid personal injury:

- Do not attempt to mount a tire on a rim. This should be done by a qualified person with the proper equipment.
- Always maintain the correct tire pressure. Do not inflate tires above the recommended pressure shown in the operator's manual.

### IMPORTANT :

- Do not use tires other than those approved by KUBOTA.

### ■ Inflation Pressure

Though the tire pressure is factory-set to the prescribed level, it naturally drops slowly in the course of time. Thus, check it everyday and inflate as necessary.

| Tire sizes   | Inflation Pressure                            |
|--|---|
| 24 x 9 - 12 HDWS, Front<br>24 x 11 - 12 HDWS, Rear | 97 kPa<br>(0.97 kgf/cm <sup>2</sup> , 14 psi) |
| 24 x 9 - 12 ATV, Front<br>24 x 11 - 12 ATV, Rear   |   |

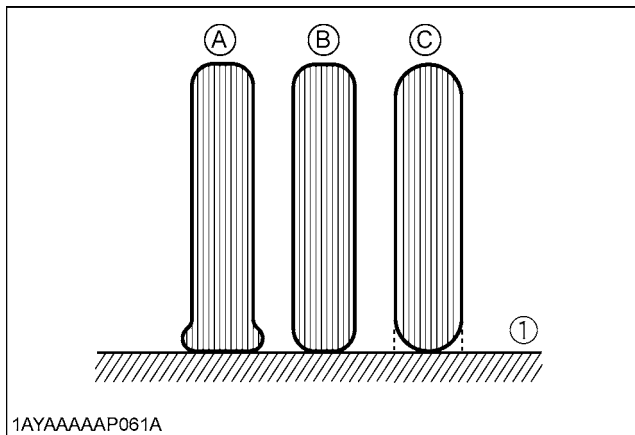

1AYAAAAAP061A

(1) Ground

(A) "INSUFFICIENT"

(B) "NORMAL"

(C) "EXCESSIVE"

### ■ Tire Type and Use

#### ◆ Heavy duty work site tire

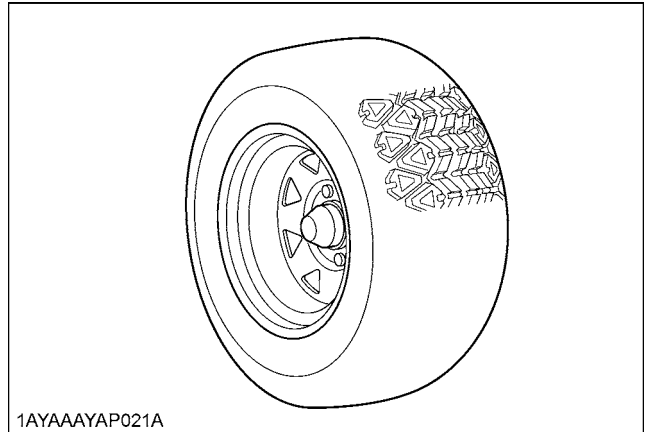

1AYAAAAAP021A

#### ◆ All terrain vehicle tire

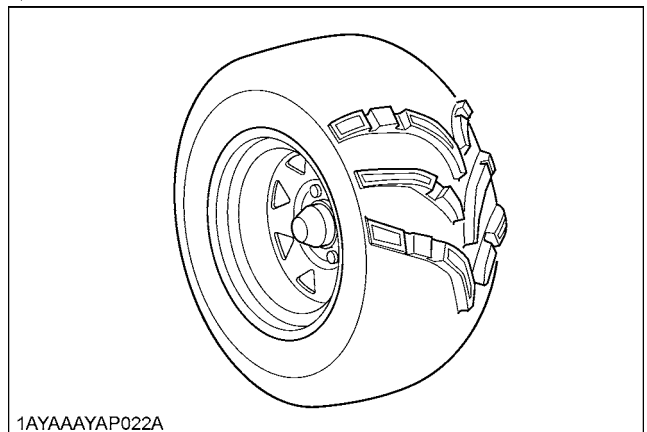

1AYAAAAAP022A



## WHEELS



### CAUTION

To avoid personal injury:

- Support vehicle securely on stands before removing a wheel.
- Never operate vehicle with loose wheel bolts.

### IMPORTANT :

- When re-fitting a wheel, tighten the bolts to the following torques then recheck after driving the vehicle 200 m (200 yards) and thereafter according to service interval.

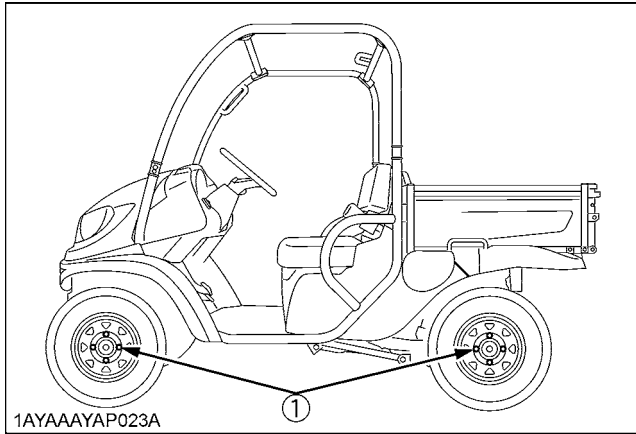

(1) Torque wheel bolts to 108.4 to 121.9 N-m  
(11 to 12.4 kgf-m) (80 to 90 lbf-ft)

## SHOCK ABSORBERS

### ■ Rear Shock Absorber Spring Adjustment



### CAUTION

To avoid personal injury:

- Be sure to work on a firm, flat and level surface with the engine shut off and parking brake "ON".
- Keep the position of the left and right rear shock absorber equal.  
Uneven adjustment can cause poor handling and loss of control, which could lead to an accident.

The spring adjusting sleeves on the rear shock absorbers have 5 positions so that the springs can be adjusted for different riding and loading conditions.

For adjusting the rear shock absorber springs, turn the adjusting sleeves on the shock absorbers to the desired position with the hook wrench.

### [Rear shock absorber position]

| Position    | Spring   | Feeling | Load  |
|-------------|----------|---------|-------|
| 1           | Stronger | Hard    | Heavy |
| 2           | ↑        | ↑       | ↑     |
| 3 (default) |          |         |       |
| 4           | ↓        | ↓       | ↓     |
| 5           | Weaker   | Soft    | Light |

### NOTE :

- If you feel any difficulty in the adjustment, consult your local KUBOTA dealer.

The rear shock absorber spring is adjusted to third position (default) in the figure below.

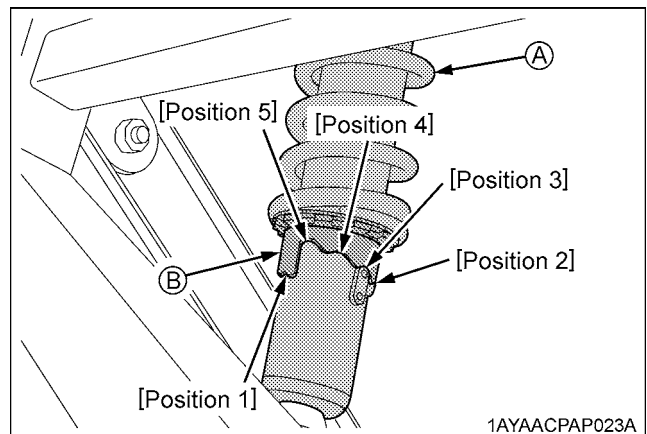

(A) Rear shock absorber

(B) Adjusting sleeve (Turn here with a hook wrench.)

# TOWING AND TRANSPORTING

## TOWING AND TRANSPORTING

### ■ Rear Trailer Hitch

[if equipped]



#### WARNING

To avoid personal injury:

- Always tow a load slowly enough to maintain control and avoid tipping.
- To provide adequate braking ability and traction, do not tow a load unless vehicle cargo bed is loaded or attachment is installed.
- Attach a trailer to the trailer hitch only.

The rear trailer hitch load is listed in the "VEHICLE LIMITATIONS" section. When towing other equipment, use a safety chain.

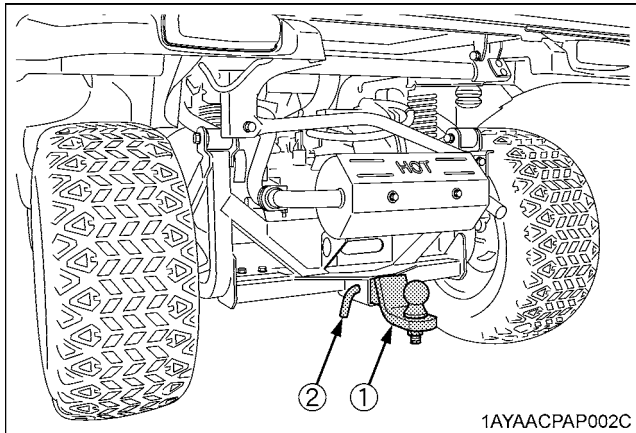

- (1) Rear trailer hitch (if equipped)  
(2) Hitch pin (if equipped)

### ■ Front Trailer Hitch

[if equipped]



#### WARNING

To avoid personal injury:

- Do not tow this vehicle unless all the functions of the vehicle are properly working, since the malfunction of steering operation or braking may cause an accident.

Use the front trailer hitch for greater maneuverability in confined areas such as a barn.

The front trailer hitch load is listed in the "VEHICLE LIMITATIONS" section.

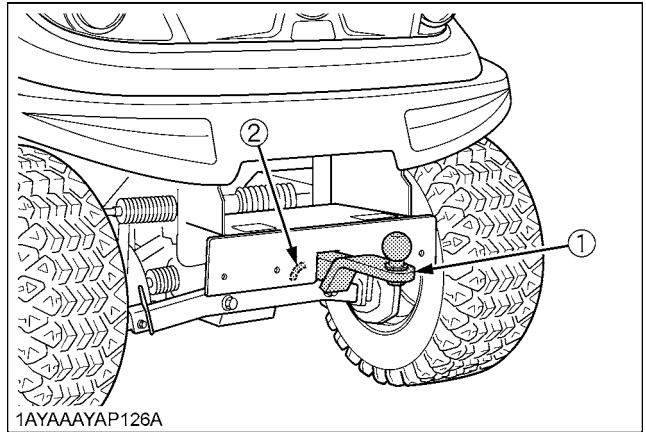

- (1) Front trailer hitch (if equipped)  
(2) Hitch pin (if equipped)

■ **Winch Mount Bracket**

[if equipped]

Mounting the optional winch always requires reading the instruction manual attached to the winch thoroughly before using it.

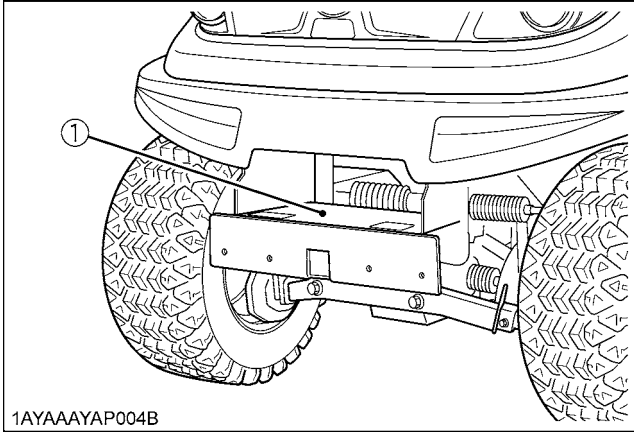

(1) Winch mount bracket (if equipped)



# 34 MAINTENANCE

| No. | Items   |         | Indication of Hour Meter |    |     |     |     |     |     |     |     |     |     |     |     |     | After 700 hrs | Ref. Page     |    |     |
|-----|---|---------|--------------------------|----|-----|-----|-----|-----|-----|-----|-----|-----|-----|-----|-----|-----|---------------|---------------|----|-----|
|     |   |         | 20                       | 50 | 100 | 150 | 200 | 250 | 300 | 350 | 400 | 450 | 500 | 550 | 600 | 650 |               |               |    | 700 |
| 9   | Toe-in  | Adjust  |                          |    | ○   |     | ○   |     | ○   |     | ○   |     | ○   |     | ○   |     | ○             | every 100 hrs | 53 |     |
| 10  | Spark arrester                                  | Clean   |                          |    | ○   |     | ○   |     | ○   |     | ○   |     | ○   |     | ○   |     | ○             | every 100 hrs | 54 |     |
| 11  | Parking brake lever                             | Adjust  |                          | ⊙  |     |     | ○   |     |     |     | ○   |     |     |     | ○   |     |               | every 200 hrs | 54 | *4  |
| 12  | Engine oil filter                               | Replace | ☆                        |    |     |     | ○   |     |     |     | ○   |     |     |     | ○   |     |               | every 200 hrs | 55 |     |
| 13  | Engine oil                                      | Change  | ☆                        |    | ○   |     | ○   |     | ○   |     | ○   |     | ○   |     | ○   |     | ○             | every 100 hrs | 47 |     |
| 14  | Engine cooling air inlet and Engine cooling fin | Check   |                          |    |     |     | ○   |     |     |     | ○   |     |     |     | ○   |     |               | every 200 hrs | 55 |     |
| 15  | CVT belt  | Check   |                          | ⊙  |     |     | ○   |     |     |     | ○   |     |     |     | ○   |     |               | every 200 hrs | 58 | *4  |
| 16  | Transmission oil                                | Change  |                          |    |     |     |     |     |     |     | ○   |     |     |     |     |     |               | every 400 hrs | 59 |     |
| 17  | Spark plug condition and gap                    | Check   |                          |    | ○   |     | ○   |     | ○   |     | ○   |     | ○   |     | ○   |     | ○             | every 100 hrs | 49 |     |
| 18  | Brake pedal                                     | Check   |                          | ⊙  |     |     | ○   |     |     |     | ○   |     |     |     | ○   |     |               | every 200 hrs | 56 | *4  |
| 19  | Brake hose & pipe                               | Check   |                          | ⊙  |     |     | ○   |     |     |     | ○   |     |     |     | ○   |     |               | every 200 hrs | 56 |     |
|     |   | Replace |                          |    |     |     |     |     |     |     |     |     |     |     |     |     |               | every 4 years | 61 | *4  |
| 20  | Brake light switch                              | Check   |                          | ⊙  |     |     | ○   |     |     |     | ○   |     |     |     | ○   |     |               | every 200 hrs | 57 |     |
| 21  | Intake air line (Engine)                        | Check   |                          |    |     |     | ○   |     |     |     | ○   |     |     |     | ○   |     |               | every 200 hrs | 57 |     |
|     |   | Replace |                          |    |     |     |     |     |     |     |     |     |     |     |     |     |               | every 2 years | 61 | *3  |
| 22  | Intake air line (CVT)                           | Check   |                          |    |     |     | ○   |     |     |     | ○   |     |     |     | ○   |     |               | every 200 hrs | 58 |     |
|     |   | Replace |                          |    |     |     |     |     |     |     |     |     |     |     |     |     |               | every 2 years | 61 | *3  |
| 23  | Tire wear                                       | Check   |                          | ⊙  |     |     |     |     | ○   |     |     |     |     |     | ○   |     |               | every 300 hrs | 58 |     |
| 24  | Front axle case oil                             | Change  |                          |    |     |     |     |     |     |     | ○   |     |     |     |     |     |               | every 400 hrs | 60 |     |
| 25  | Engine valve clearance                          | Adjust  |                          |    |     |     |     |     | ○   |     |     |     |     |     | ○   |     |               | every 300 hrs | 58 |     |
| 26  | Engine combustion chamber                       | Clean   |                          |    |     |     |     |     |     |     |     |     |     | ○   |     |     |               | every 500 hrs | 60 |     |
| 27  | Brake fluid                                     | Change  |                          |    |     |     |     |     |     |     |     |     |     |     |     |     |               | every 2 years | 61 | *4  |
| 28  | Brake master cylinder (inner parts)             | Replace |                          |    |     |     |     |     |     |     |     |     |     |     |     |     |               | every 2 years | 61 | *4  |
| 29  | Engine breather hose                            | Replace |                          |    |     |     |     |     |     |     |     |     |     |     |     |     |               | every 2 years | 61 |     |

| No. | Items          |         | Indication of Hour Meter |    |     |     |     |     |     |     |     |     |     |     |     |     | After<br>700 hrs | Ref.<br>Page              |    |     |
|-----|----------------|---------|--------------------------|----|-----|-----|-----|-----|-----|-----|-----|-----|-----|-----|-----|-----|------------------|---------------------------|----|-----|
|     |                |         | 20                       | 50 | 100 | 150 | 200 | 250 | 300 | 350 | 400 | 450 | 500 | 550 | 600 | 650 |                  |                           |    | 700 |
| 30  | Brake pad wear | Check   |                          |    |     |     |     |     |     |     |     |     |     |     |     |     |                  | Service<br>as<br>required | 61 | *4  |
| 31  | Parking brake  | Adjust  |                          |    |     |     |     |     |     |     |     |     |     |     |     |     |                  |                           | 62 | *4  |
| 32  | Fuse           | Replace |                          |    |     |     |     |     |     |     |     |     |     |     |     |     |                  |                           | 62 |     |
| 33  | Light bulb     | Replace |                          |    |     |     |     |     |     |     |     |     |     |     |     |     |                  |                           | 64 |     |

## LUBRICANTS AND FUEL

| No. | Locations                         | Capacities   | Lubricants  |
|-----|-----------------------------------|--|---|
| 1   | Fuel                              | 20 L (5.3 U.S.gals.)   | <ul style="list-style-type: none"> <li>● Automobile unleaded or regular gasoline</li> <li>● Unleaded gasoline 87 octane or higher</li> <li>● Gasohol (E10 or less)</li> </ul>               |
| 2   | Engine crankcase                  | [Filter exchanged]<br>1.6 L (1.7 U.S.qts.)**<br>[Filter non-exchanged]<br>1.4 L (1.5 U.S.qts.)** | <ul style="list-style-type: none"> <li>● Engine oil: API Service Classification SG, SH, SJ or higher</li> </ul> Above -18 °C (0 °F)...SAE10W-30<br>Below 0 °C (32 °F).....SAE5W-20 or 5W-30 |
| 3   | Transmission case                 | 5.4 L (1.4 U.S.gals.)  | ● KUBOTA UDT or SUPER UDT-2 fluid*  |
| 4   | Front axle case                   | 0.21 L (0.22 U.S.qts.)   | ● KUBOTA UDT or SUPER UDT-2 fluid*  |
| 5   | Brake fluid (reservoir and lines) | 0.2 L (0.21 U.S.qts.)  | <b>KUBOTA DOT3 GENUINE BRAKE FLUID</b>  |

| Greasing                     | No. of greasing points | Capacity        | Type of grease    |
|------------------------------|------------------------|-----------------|-------------------|
| Battery terminal             | 2                      | Moderate amount | Spray Type Grease |
| Cargo bed pivot              | 2                      |                 |                   |
| Parking brake pivot          | 2                      |                 |                   |
| Range gear shift lever pivot | 1                      |                 |                   |
| 4WD lever pivot              | 1                      |                 |                   |
| Differential lock lever      | 1                      |                 |                   |

### NOTE :

\*KUBOTA UDT or SUPER UDT-2 fluid --- KUBOTA original transmission hydraulic fluid

\*\*Oil amount when the oil level is at the upper level of the oil level gauge.

### NOTE :

#### ◆ Engine Oil:

Oil used in the engine should have an American Petroleum Institute (API) service classification and Proper SAE Engine Oil according to the ambient temperatures as shown above:

#### ◆ Fuel:

- Gasohol (up to 10% ethyl alcohol, 90% unleaded gasoline by volume) is approved for the engine. Other gasoline/ alcohol blends are not approved.

#### ◆ Transmission oil:

To complete lubrication of the transmission, it is important that a multi-grade transmission fluid be used in this system. We recommend the use of **KUBOTA UDT or SUPER UDT-2 fluid** for optimum protection and performance. (Consult your local KUBOTA Dealer for further detail.)

Do not mix different brands or grades.

#### ◆ Brake fluid:

Always use KUBOTA **DOT3 GENUINE BRAKE FLUID** from a sealed container. If it is not available, you should use only DOT3 fluid as a temporary replacement from a sealed container.

However, the use of any non-KUBOTA brake fluid can cause corrosion and decrease the life of the system.

Have the brake system flushed and refilled with KUBOTA **DOT3 GENUINE BRAKE FLUID** as soon as possible.

- Indicated capacity of water and oil are manufacturer's estimate.

# PERIODIC SERVICE



## CAUTION

To avoid personal injury:

- Do not work under any hydraulically supported devices. They can settle, suddenly leak down, or be accidentally lowered. If necessary to work under vehicle or any vehicle elements for servicing or adjustment, securely support them with stands or suitable blocking beforehand.

## HOW TO OPEN THE HOOD AND TILT THE SEAT



## CAUTION

To avoid personal injury from contact with moving parts;

- Never open the operator's seat while the engine is running.

### ■ Hood

1. To open the hood, pull up the latch lever to release the latch and open the hood.
2. Push the support link into the hole to lock when the hood is fully raised.

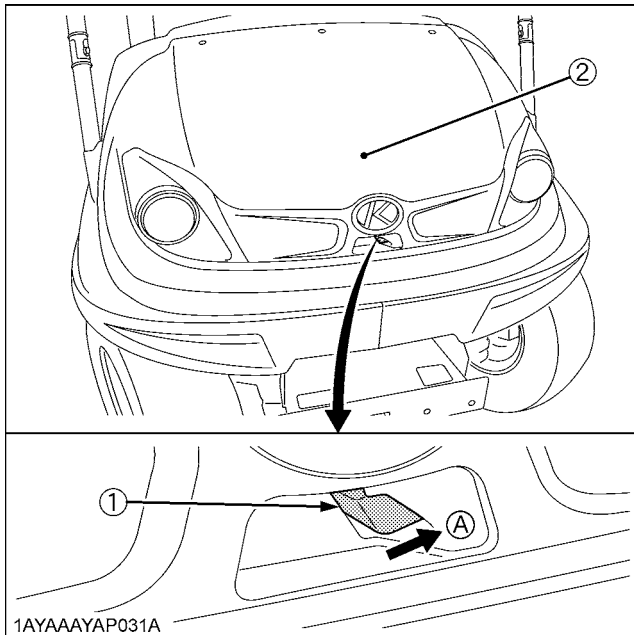

(1) Latch lever  
(2) Hood

(A) "RELEASE"

5. Press-fit the hood into position with both hands.

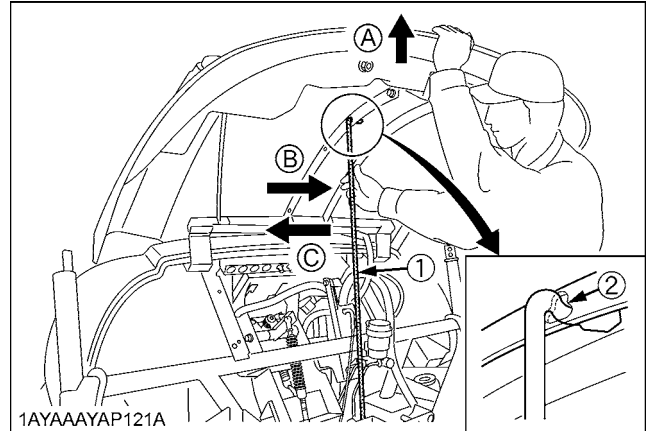

(1) Support link  
(2) Hole

(A) "HOLD"  
(B) "PUSH" (Lock)  
(C) "PULL" (Unlock)

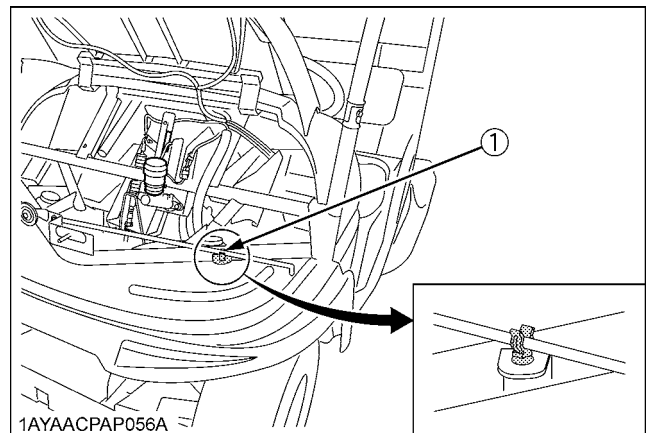

(1) Support holder

3. To close the hood, hold the hood and lift up it slightly and pull the support link to unlock.
4. Put the support link into the support holder.



### ■ Operator's Seat

To open the seat, raise the seat to the forward position.

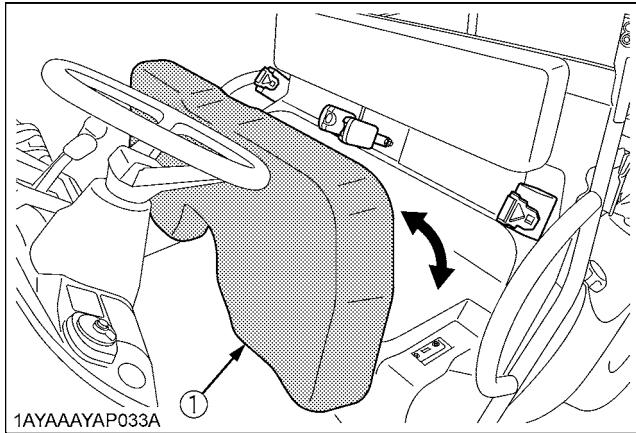

(1) Operator's seat

## HOW TO RAISE THE CARGO BED



### CAUTION

To avoid personal injury:

- When servicing under raised bed, make sure safety support is properly mounted.
- Do not touch muffler or exhaust pipes while they are hot; Severe burns could result.

### ■ Raising and Lowering the Cargo Bed



### CAUTION

To avoid personal injury;

- Make sure the vehicle is on a firm, level surface and the parking brake is applied before raising the cargo bed and securing the cargo bed in the raised position.
- A loaded cargo bed can be very heavy. Never raise the cargo bed when it is loaded. Unload the cargo bed before raising it by hand.

1. Park the vehicle on a flat surface.
2. Empty the cargo bed by hand.
3. Release the latches on both sides and then raise the cargo bed with the hand grip.

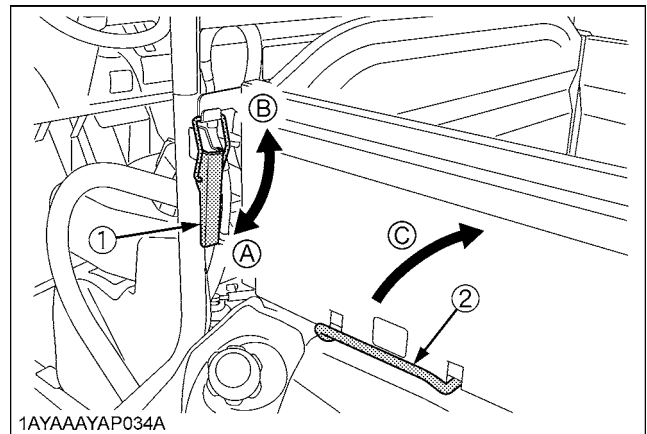

(1) Latch

(2) Hand grip

(A) "LOCK"

(B) "RELEASE"

(C) "RAISE"

4. Push the safety support into the latch slot to lock when the cargo is fully raised.

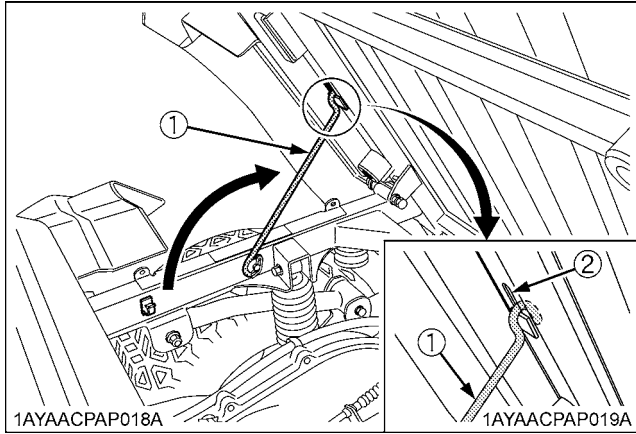

(1) Safety support  
(2) Latch slot

5. To lower the cargo bed, raise the cargo bed slightly using the handgrip.
6. Release the safety support from the latch slot by pulling up on the middle of the support.
7. Put the safety support into the support holder.

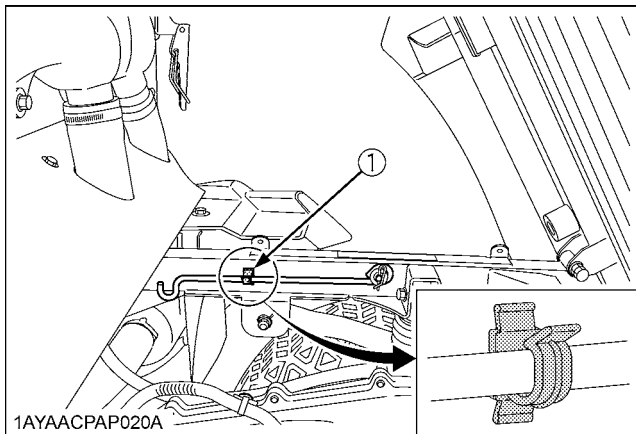

(1) Support holder

8. Slowly lower the cargo bed onto the frame and set the latches on both sides.

## JACK-UP POINT

### WARNING

To avoid personal injury, death or vehicle damage:

- Do not work under the vehicle unless it is secured by safe stands or suitable blocking.

#### ■ Front End

Jack up at the front bumper only.

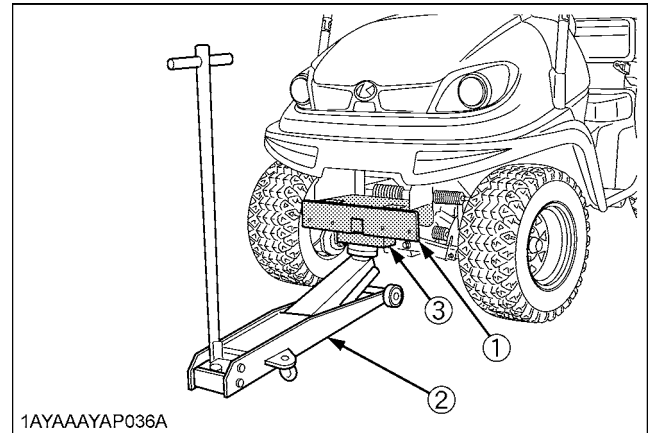

(1) Front bumper  
(2) Jack  
(3) Wooden block

#### ■ Rear End

Jack up the rear side after placing a wooden block under the transmission bottom cover for securing the engine and then supporting it.

Do not jack it up supporting the steel plate portion under the transmission bottom cover directly.

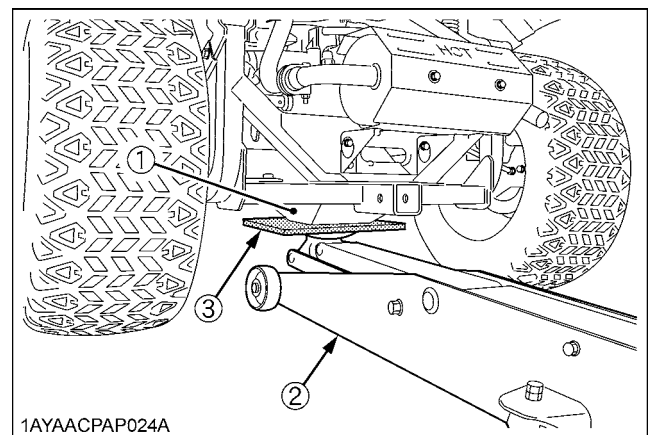

(1) Transmission bottom cover  
(2) Jack  
(3) Wooden block

## DAILY CHECK

For your own safety and maximum service life of the vehicle, make a thorough daily inspection before operating the vehicle to start the engine.



### CAUTION

To avoid personal injury:

- Be sure to check and service the vehicle on a flat surface with the engine shut off and the parking brake "ON".

### ■ Walk Around Inspection

Look around and under the vehicle for such items as loose bolts, trash build-up, oil or coolant leaks, broken or worn parts.

### ■ Checking Amount of Fuel and Refueling



### CAUTION

To avoid personal injury:

- Handle fuel carefully. If the engine is running, do not fill the fuel tank. If engine is hot, let engine cool several minutes before adding fuel. Do not smoke while filling the fuel tank or servicing the fuel system. Fill fuel tank only to bottom of filler neck. Do not fill completely full. The empty space in the tank allows gasoline to expand, when it heats up. Never remove the fuel tank cap or add fuel when the fuel tank is hot.



1BDABARAP121A

Check the fuel level. Take care that the fuel tank does not become empty.

|                    |                      |
|--------------------|----------------------|
| Fuel tank capacity | 20 L (5.3 U.S.gals.) |
|--------------------|----------------------|

### IMPORTANT :

- Do not mix oil with gasoline.

Use only unleaded gasoline with an octane rating index of 87 or higher may be used.

### NOTE :

- Use fuel within approximately 30 days after purchase to avoid deterioration in fuel quality, or add fuel stabilizer to keep fuel fresh and stabilized.
- Fuel blend differs from season to season for the best seasonal engine performance. To prevent engine performance troubles such as vapor lock or hard starting, use fuel within the season in which the fuel is purchased.
- Infrequent use of the engine during a season can make fuel stale in the fuel tank of the machine. Stale fuel condition can cause engine performance troubles by varnish and plugged carburetor components.
- Seal the fuel storage container tightly and store it out of sunlight and heat to prevent fuel degradation.
- Condensation in the fuel tank may occur because of various operating or environmental conditions. To reduce condensation and avoid affecting machine operation, fill the fuel tank at the end of daily operation and store fuel in the plastic container.

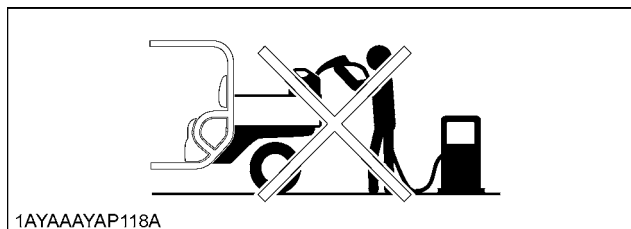

1AYAAAYAP118A

- Use only an approved fuel container. Use only non-metal, portable fuel containers approved by the Underwriter's Laboratory (U.L.) or the American Society for Testing & Materials (ASTM). If using a funnel, make sure it is plastic and has no screen or filter.
- Never remove the fuel tank cap or add fuel with the engine running. Allow the engine to cool before refueling.
- Never add fuel to or drain fuel from the machine indoors. Move the machine outdoors and provide adequate ventilation.
- Clean up spilled fuel immediately. If fuel is spilled on clothing, change clothing immediately. If fuel is spilled near machine, do not attempt to start the engine but move the machine away from the area of spillage. Avoid creating any source of ignition until fuel vapors have dissipated.
- Never store the machine or fuel container where there is an open flame, spark, or pilot light such as on a water heater or other appliance.
- Prevent fire and explosion caused by static electric discharge. Static electric discharge can ignite fuel vapors in an ungrounded fuel container.
- Never fill containers inside a vehicle or on a truck or a trailer bed with a plastic liner. Always place containers on the ground away from your vehicle before fueling.

- Remove fuel-powered equipment from the truck or the trailer and refuel it on the ground. If this is not possible, then refuel such equipment with a portable container, rather than from a fuel dispenser nozzle.
- Keep the nozzle in contact with the rim of the fuel tank or container opening at all times until the fueling is complete. Do not use a nozzle lock-open device.
- Never overfill fuel tank. Replace the fuel tank cap and tighten securely.
- Replace all fuel container caps securely after use.
- For gasoline engines, do not use gas with methanol. Methanol is harmful to your health and to the environment.

**IMPORTANT :**

- Do not use stale fuel.
- Fill fuel tank at the end of daily operation to prevent condensation in the fuel tank.

**[Use of alcohol mixed gasoline (Gasohol: E10 or less)]**

Use "gasohol" only when the ethanol additive is less than 10% of the fuel. The use of methanol additive is not recommended. For the best results, use unleaded fuel with a minimum of 87 octane.

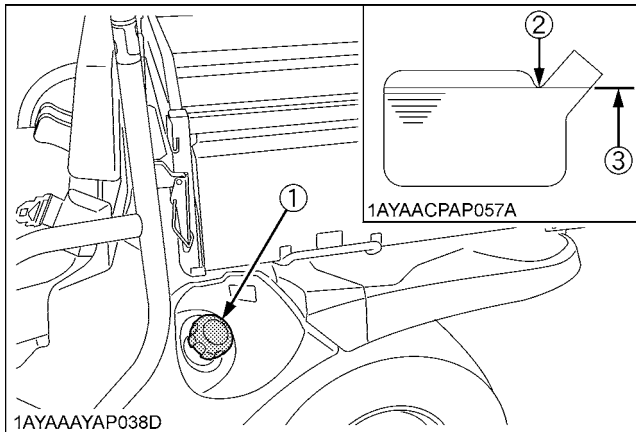

- (1) Fuel tank cap
- (2) Fuel tank filler neck
- (3) Max. fuel level

**■ Checking Engine Oil Level**

**⚠ CAUTION**

To avoid personal injury:

- Be sure to stop the engine before checking the oil level.

1. Park the vehicle on a flat surface and raise the cargo bed. Shut off the engine and remove the key.
2. Allow the engine to cool for 5 minutes or more.
3. To check the oil level, draw out the dipstick, wipe it clean, reinstall it, and draw it out again. Check to see that the oil level lies between the two notches. If the level is too low, add new oil to the prescribed level at the oil inlet.  
(See "LUBRICANTS AND FUEL" in "MAINTENANCE" section.)

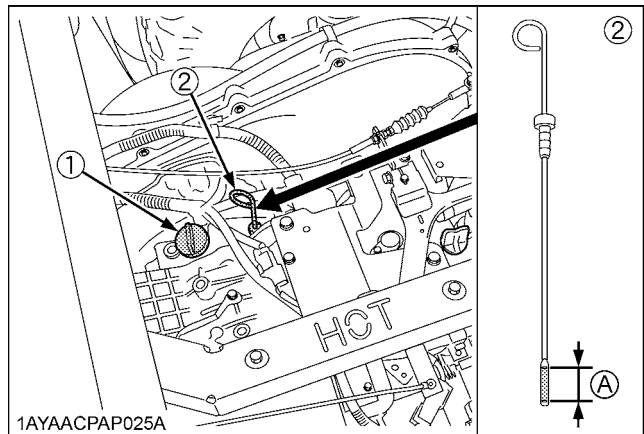

- (1) Oil inlet
- (2) Dipstick
- (A) Oil level is acceptable within this range.

**IMPORTANT :**

- When using an oil of different maker or viscosity from the previous one, remove all of the old oil. Never mix two different types of oil.
- If oil level is low, do not run engine.
- Clean the area around dipstick and oil inlet before removing or loosening them, and be careful not to allow the dust go into the engine.

## ■ Checking Transmission Fluid Level

1. Park the vehicle on a flat surface and raise the cargo bed. Shut off the engine and remove the key.
2. Allow the engine to cool for 5 minutes or more.
3. To check the oil level, draw out the dipstick, wipe it clean, reinstall it, and draw it out again. Check to see that the oil level lies between the two notches. If the level is too low, add new oil to the prescribed level at the oil inlet.  
(See "LUBRICANTS AND FUEL" in "MAINTENANCE" section.)

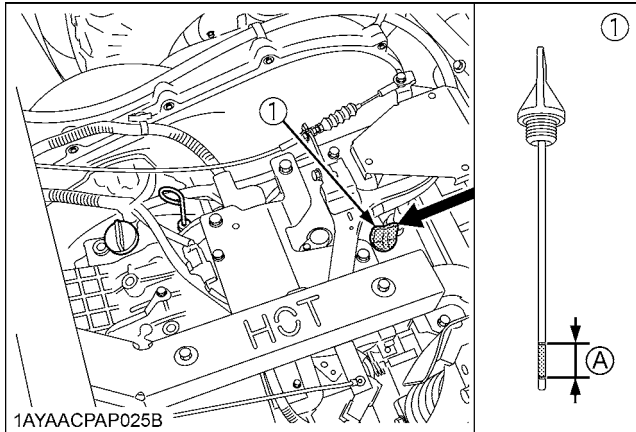

(1) Dipstick (A) Oil level is acceptable within this range.

### IMPORTANT :

- If oil level is low, do not run engine.

## ■ Checking Brake Fluid Level



### CAUTION

To avoid personal injury:

- Never operate the vehicle, if the brake fluid is below the "MIN" mark.
- Use only KUBOTA DOT3 GENUINE BRAKE FLUID from a sealed container. Using other type of oil ruins synthetic resin or rubber installed in brake system components, and may cause brake failure.
- Avoid contamination of the brake fluid. Thoroughly clean area around the filler cap before removing. Do not open the brake fluid reservoir cap unless absolutely necessary.
- Use extreme care when filling the reservoir. If brake fluid is spilled on power steering hose, wash off with water immediately. Brake fluid quickly ruins synthetic resin or rubber hoses.

1. Park the vehicle on a level ground and open the hood.
2. Check to see that the brake fluid level is between the "MAX" and "MIN" marks.
3. If it is below the "MIN" mark, add brake fluid to the "MAX" mark.

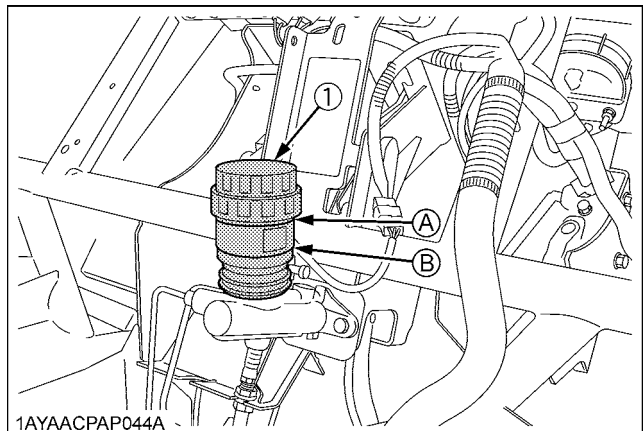
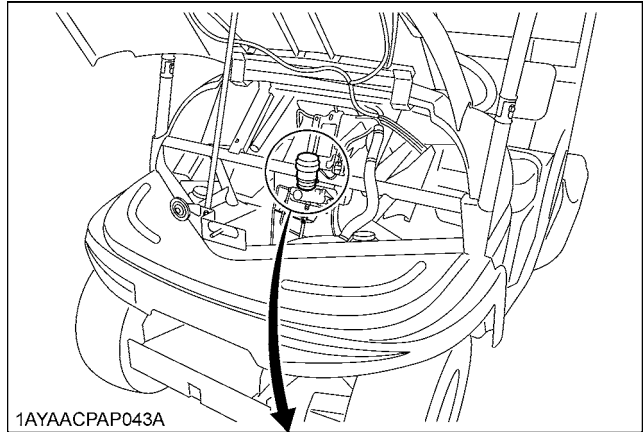

(1) Oil tank cap

(A) "MAX"

(B) "MIN"

### ■ Checking Brake Pedal



#### CAUTION

To avoid personal injury:

- Stop the engine and chock the wheels before checking brake pedal.

1. Inspect the brake pedals for free travel, and smooth operation.
2. Adjust if incorrect measurement is found: (See "Checking Brake Pedal" in "EVERY 200 HOURS" in "PERIODIC SERVICE" section.)

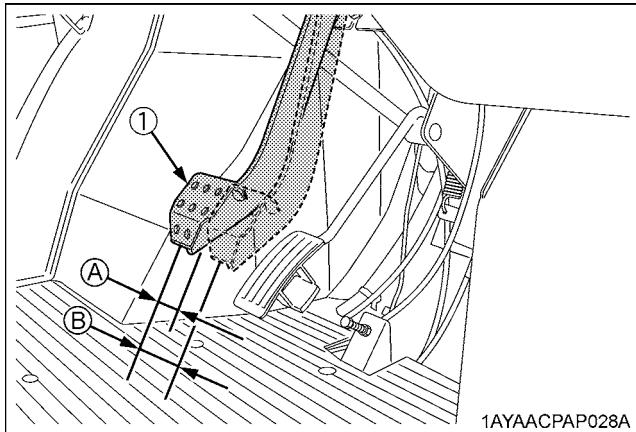

(1) Brake pedal

(A) "FREE TRAVEL"  
(B) "PEDAL STROKE"

### ■ Checking Parking Brake

Pull the parking brake lever to apply the brakes. With the key switch at "ON" position, the brake indicator on the instrument panel lights up. To release the brakes, push in the button at the tip of the parking brake lever and tilt down the lever.

#### NOTE :

- Make sure the brake indicator light on the Easy Checker(TM) goes off when parking brake lever is down.

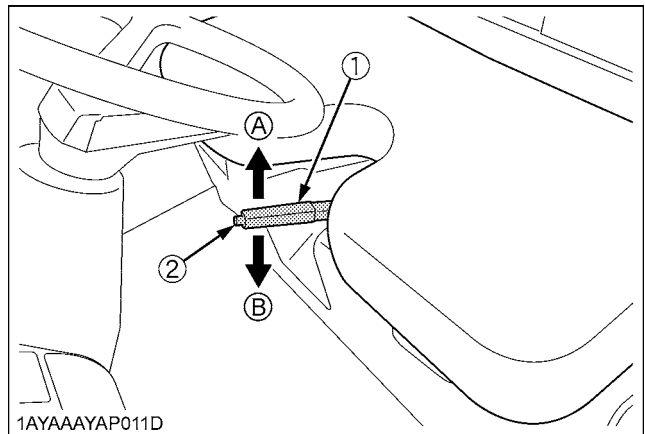

(1) Parking brake lever  
(2) Release button

(A) "PULL"  
(B) "RELEASE"

### ■ Checking Gauges, Meter and Easy Checker(TM)

1. Inspect the instrument panel for broken gauge(s), meter(s) and Easy Checker(TM) lamps.
2. Replace if broken.

### ■ Checking Head Light, etc.

1. Inspect the lights for broken bulbs and lenses.
2. Replace if broken.

### ■ Checking Seat Belt and ROPS

1. Always check condition of seat belt and ROPS attaching hardware before operating vehicle.
2. Replace if damaged.

**■ Checking Joint Boot**

1. Check to see if the joint boots are not damaged.
2. If the boots are cuts, cracked or shows signs of deterioration, consult your local KUBOTA Dealer.

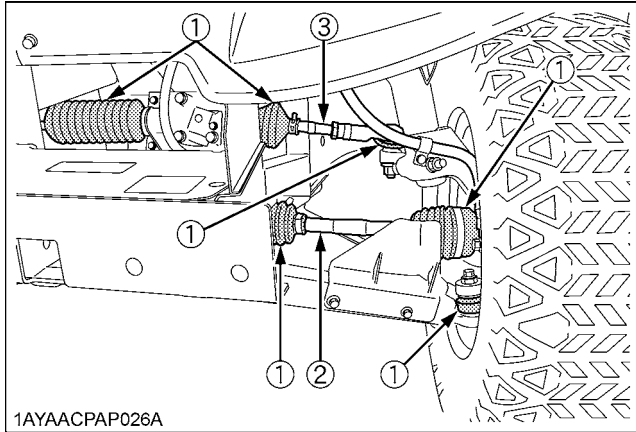

- (1) Joint boot
- (2) Front drive shaft
- (3) Tie rod

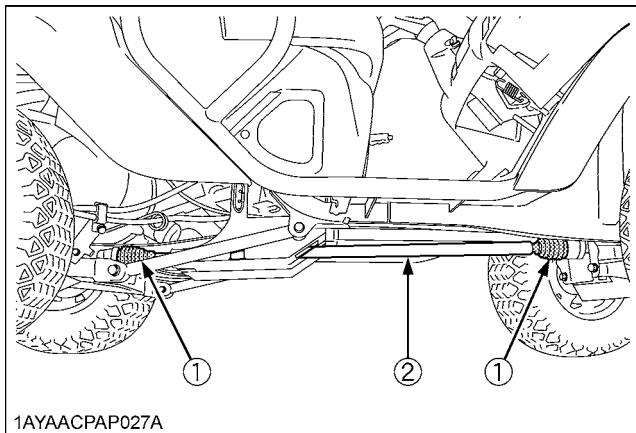

- (1) Joint boot
- (2) Drive shaft

**■ Checking Tire Inflation Pressure**

Though the tire pressure is factory-set to the prescribed level, it naturally drops slowly in the course of time. Thus, check it everyday and inflate as necessary.

| Tire sizes   | Inflation Pressure                            |
|--|---|
| 24 x 9 - 12 HDWS,<br>Front<br>24 x 11 - 12 HDWS,<br>Rear | 97 kPa<br>(0.97 kgf/cm <sup>2</sup> , 14 psi) |
| 24 x 9 - 12 ATV,<br>Front<br>24 x 11 - 12 ATV,<br>Rear   |   |

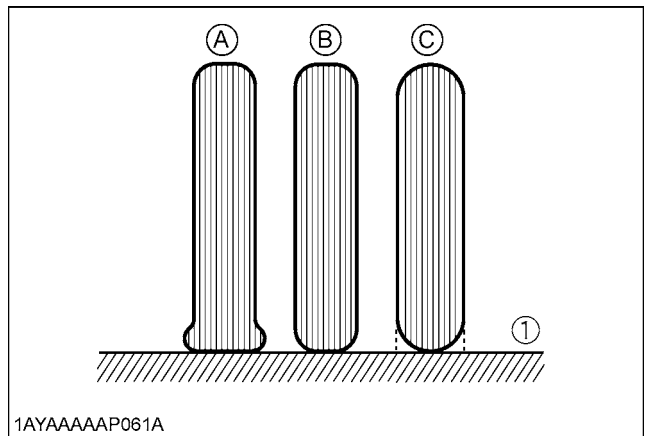

- (1) Ground
- (A) "INSUFFICIENT"
- (B) "NORMAL"
- (C) "EXCESSIVE"

# EVERY 50 HOURS

## ■ Greasing

Apply a small amount of multi-purpose grease to the following points every 50 hours: If you operated the vehicle in extremely wet and muddy conditions, lubricate grease fittings more often.

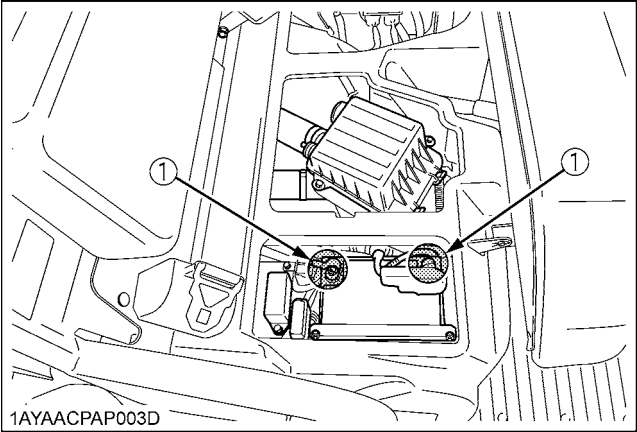

(1) Battery terminals (spray type grease)

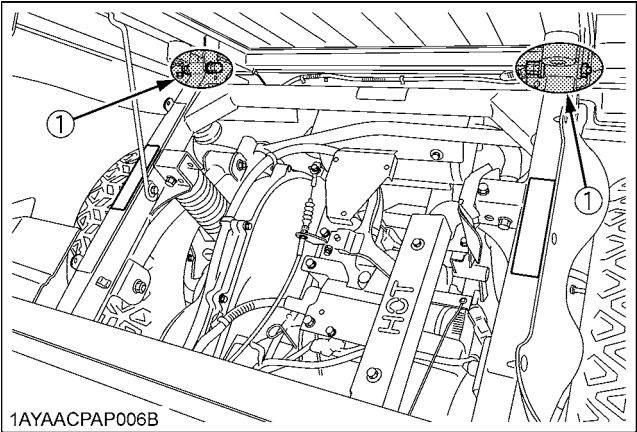

(1) Cargo bed pivot (spray type grease)

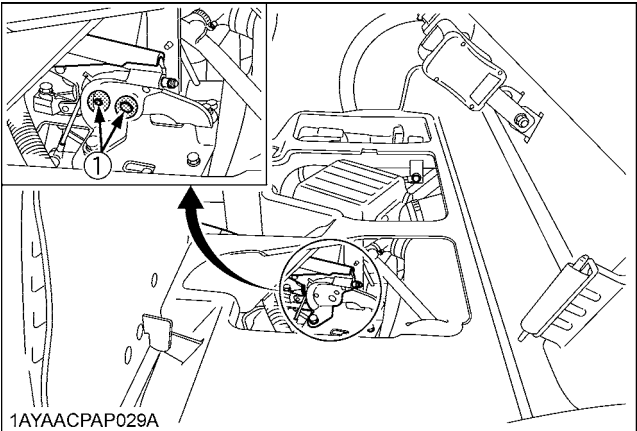

(1) Parking brake pivot (spray type grease)

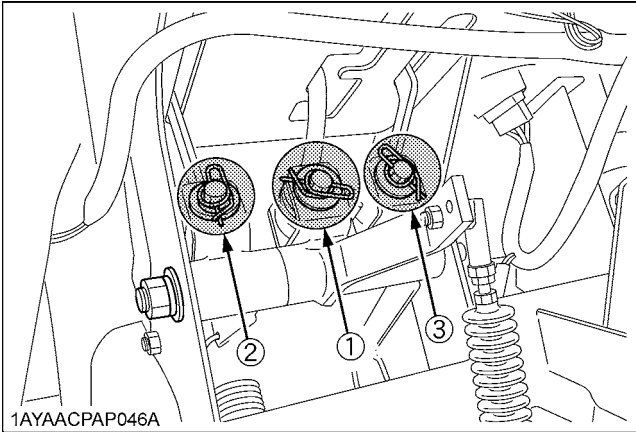
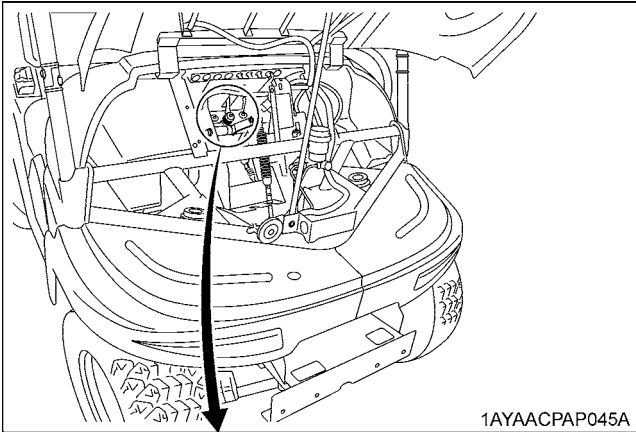

(1) Range gear shift lever pivot (spray type grease)  
(2) 4WD lever pivot (spray type grease)  
(3) Differential lock lever (spray type grease)



## ■ Checking Engine Start System



### CAUTION

To avoid personal injury:

- Do not allow anyone near the vehicle while testing.
- If the vehicle does not pass the test do not operate the vehicle.

### ◆ Preparation before testing.

1. Place all control levers in the "NEUTRAL" position.
2. Set the parking brake and stop the engine.

### ◆ Test: Range gear shift lever safety switch

1. Sit on the operator's seat.
2. Shift the range gear shift lever to "H", "L" or "R" position.
3. Return the Speed control pedal to the "N" position.
4. Turn the key to "START" position.
5. The engine must not crank.
6. If it cranks, consult your local KUBOTA Dealer for this service.

## EVERY 100 HOURS

### ■ Checking Wheel Bolt Torque



### CAUTION

To avoid personal injury:

- Never operate vehicle with a loose wheel bolts.
- Any time bolts are loosened, retighten to the specified torque.
- Check all bolts frequently and keep them tight.

Check wheel bolts regularly especially when new. If they are loose, tighten them as follows.

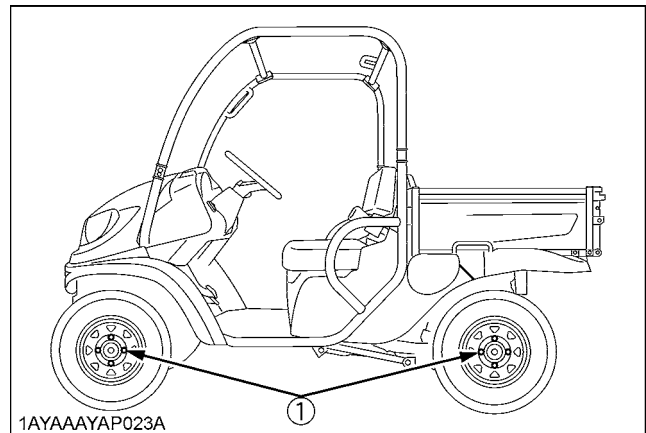

(1) Torque wheel bolts to 108.4 to 121.9 N-m  
(11 to 12.4 kgf-m) (80 to 90 lbf-ft)

### ■ Changing Engine Oil

#### CAUTION

To avoid personal injury:

- Be sure to stop the engine before changing the oil.
- Allow engine to cool down sufficiently, oil can be hot and can burn.

1. Park the vehicle on a flat surface and raise the cargo bed. Shut off the engine and remove the key.
2. To drain the used oil, remove the drain plug at the bottom of the engine and completely drain the oil into an oil pan.  
All the used oil can be drained out easily when the engine is still warm.
3. After draining, reinstall the drain plug.
4. Fill with the new oil up to the upper notch on the dipstick. Check the oil level after cranking slightly. When too much oil is added, drain out the excessive oil.  
(See "LUBRICANTS AND FUEL" in "MAINTENANCE" section.)

|              |  |
|--------------|--|
| Oil capacity | [Filter exchanged]<br>1.6 L (1.7 U.S.qts.)<br>[Filter non-exchanged]<br>1.4 L (1.5 U.S.qts.) |
|--------------|--|

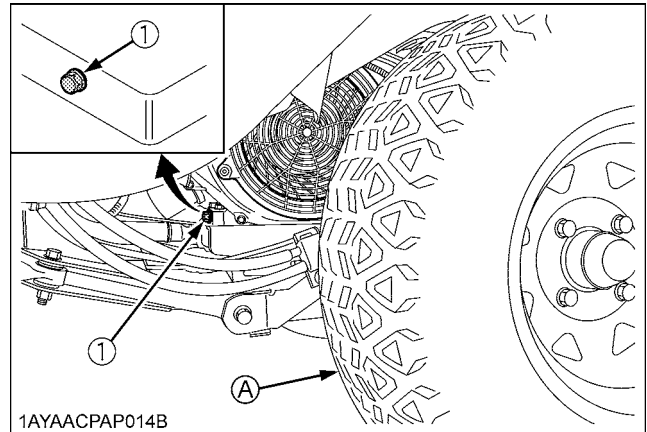

(1) Drain plug

(A) Left rear tire

#### IMPORTANT :

- When using an oil of different maker or viscosity from the previous one, remove all of the old oil. Never mix two different types of oil.
- If oil level is low, do not run engine.
- Clean the area around dipstick and oil inlet before removing or loosening them, and be careful not to allow the dust to go into the engine.

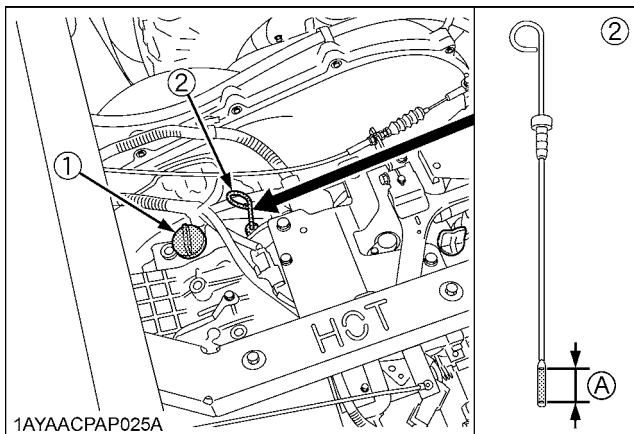

(1) Oil inlet (A) Oil level is acceptable within this range  
(2) Dipstick

### ■ Cleaning Engine Air Cleaner Element

1. Remove the air cleaner cover.
2. Blow compressed air to the end of the element and inside the air cleaner with care not to allow dust into the intake air inlet.
3. Remove the air cleaner element.
4. Clean the element:
  - (1) When dry dust adheres to the element, blow compressed air from the inside, turning the element. Pressure of compressed air must be under 205 kPa (2.1 kgf/cm<sup>2</sup>, 30 psi).
  - (2) When carbon or oil adheres to the element, replace the element with new one even if it has not been used for 1 year.
5. Replace the element:
 

Once yearly or after every sixth cleaning, whichever comes first.

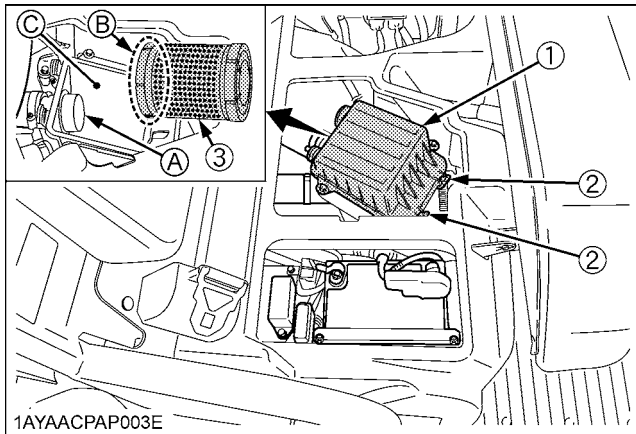

- |             |                        |
|-------------|------------------------|
| (1) Cover   | (A) Intake air inlet   |
| (2) Clamp   | (B) Element end        |
| (3) Element | (C) Air cleaner inside |

**IMPORTANT :**

- The air cleaner uses a dry element, never apply oil.
- Do not run the engine with filter element removed.
- When removing and installing the element, be careful not to allow dust into the intake air inlet.

### ■ Cleaning CVT Air Cleaner Element

1. Remove the air cleaner cover and element.
2. Clean the element:
  - (1) When dry dust adheres to the element, blow compressed air from the inside, turning the element. Pressure of compressed air must be under 205 kPa (2.1 kgf/cm<sup>2</sup>, 30 psi).
  - (2) When carbon or oil adheres to the element, replace the element with new one even if it has not been used for 1 year.
3. Replace the element:
 

Once yearly or after every sixth cleaning, whichever comes first.

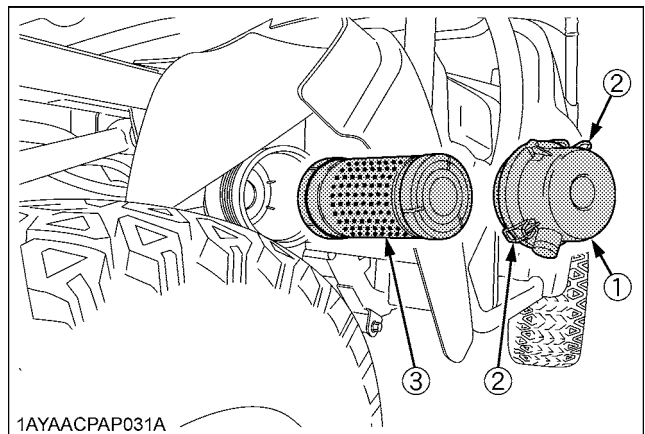
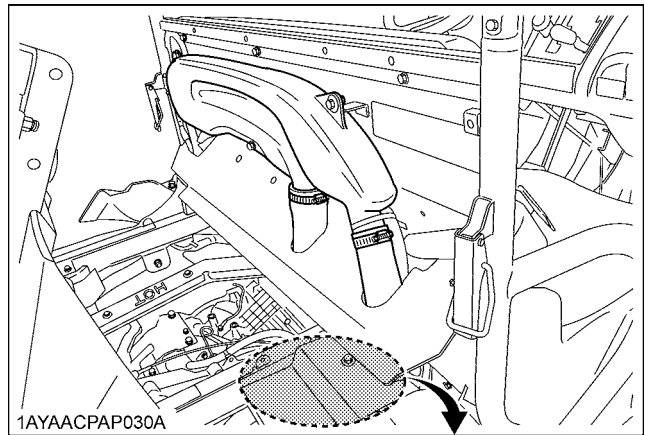

- |             |
|-------------|
| (1) Cover   |
| (2) Clamp   |
| (3) Element |

**IMPORTANT :**

- The air cleaner uses a dry element, never apply oil.
- Do not run the engine with filter element removed.

### ■Checking Spark Plug Condition & Gap

Remove the spark plugs, check condition, and reset the gap or replace with new plugs as necessary.

1. Raise the cargo bed.
2. Raise the seat.

Then remove a push rivet with unlocked, and turn over the rubber sheet.

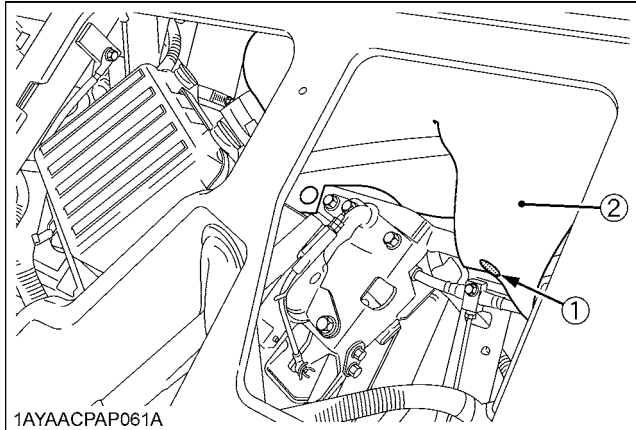

(1) Push rivet  
(2) Rubber sheet

**NOTE :**

- To remove push rivet:  
Push the pin, and set the locked rivet to the unlocked rivet.
- To install push rivet:  
Push the pin, and set the unlocked rivet to the initial rivet.  
Then set the push rivet into the hole to install, push the pin and set it to the locked rivet.

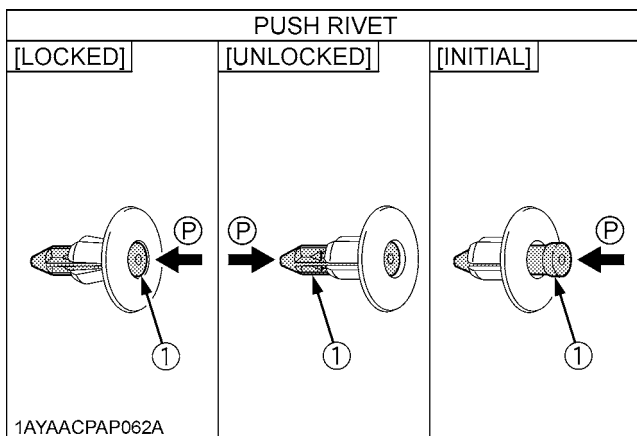

(1) Pin (P) "PUSH"

3. Before removing spark plugs, clean the area around the base of the plug to keep dirt and debris out of the engine.
4. Remove the spark plug wires from spark plugs.
5. Use a spark plug wrench to remove the spark plugs.

6. Remove plugs and check its condition.  
Replace the plug if worn or reuse is questionable.
7. Inspect spark plugs for cracked porcelain, pitted electrodes, or other wear and damage. Replace the spark plug if necessary.

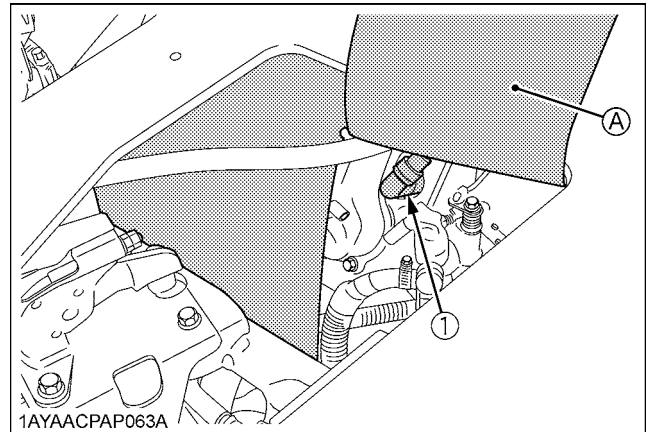

(1) Spark plug (A) Rubber sheet

**NOTE :**

- Do not clean the spark plug in a machine using abrasive grit. Some grit could remain in the spark plug and enter the engine causing extensive wear and damage.

|                        |           |
|------------------------|-----------|
| Recommended spark plug | NGK BR6HS |
|------------------------|-----------|

8. Check the gap using a wire feeler gauge. Adjust the gap from 0.6 to 0.7 mm (0.024 to 0.028 in.) by carefully bending the ground electrode.

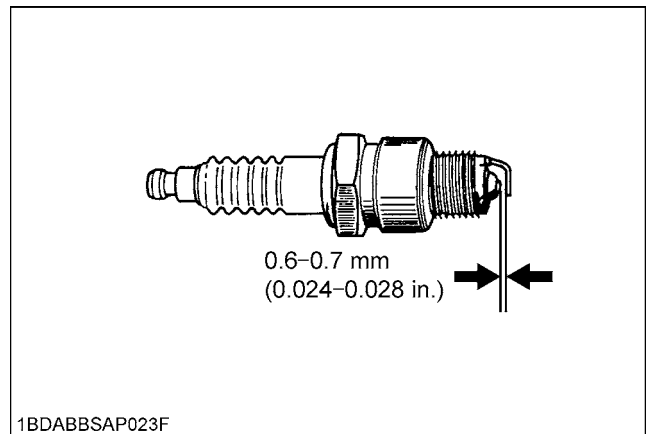

1BDABBSAP023F

9. Reinstall the spark plug into the cylinder head.

|                             |                                    |
|-----------------------------|------------------------------------|
| Tightening torque (initial) | 12 to 15 N-m<br>(8.9 to 11 lbf-ft) |
| Retightening torque         | 23 to 27 N-m<br>(17 to 19 lbf-ft)  |

■ Checking Fuel Line

**CAUTION**

To avoid personal injury:

- Be sure to stop the engine and remove the key when attempting to make the following checks and changes.
- Never fail to check the fuel lines periodically. The fuel lines are subject to wear and aging. Fuel may leak out onto the running engine, causing a fire.

The fuel line connections should be checked annually or every 100 service hours, whichever comes first.

1. Park the vehicle on a flat surface and raise the cargo bed.
2. The fuel line is made of rubber and ages regardless of service period.
3. If the fuel line and clamps are found to be damaged or deteriorated, replace them.

**IMPORTANT :**

- When the fuel line is disconnected for maintenance or repair, close both ends of the fuel line with a piece of clean cloth or paper to prevent dust and dirt from entering. In addition, particular care must be taken not to admit dust and dirt into the fuel pump. Entrance of even a small amount of dust or dirt cause premature wear and malfunction of the fuel pump and injector components.

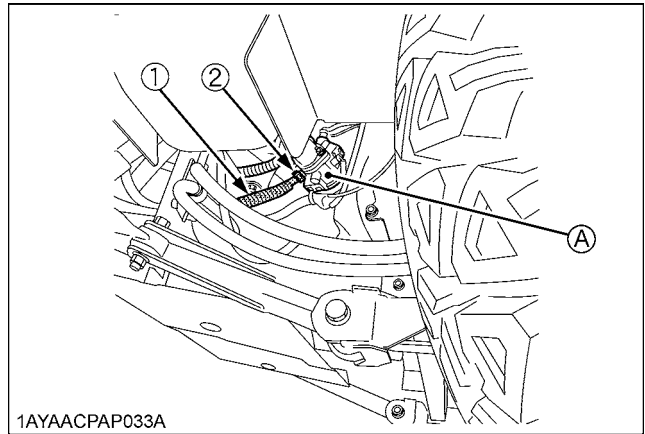

1A1YAACPAP033A

- (1) Fuel line (Carbon canister → Throttle body)  
 (2) Hose clamp  
 (A) Throttle body

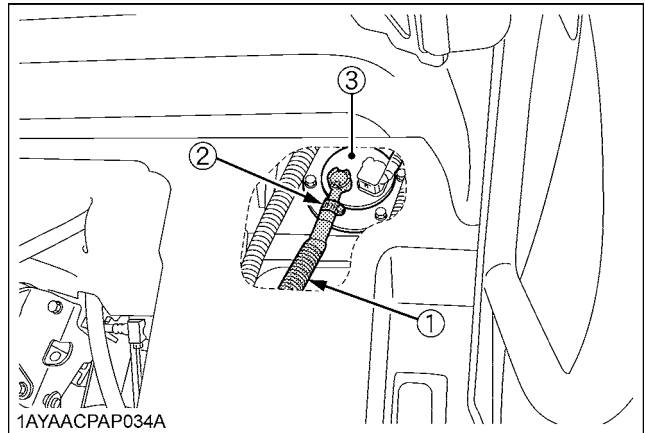

1B1YAACPAP034A

- (1) Fuel line (Fuel pump → Throttle body)  
 (2) Hose clamp  
 (3) Fuel pump with filter

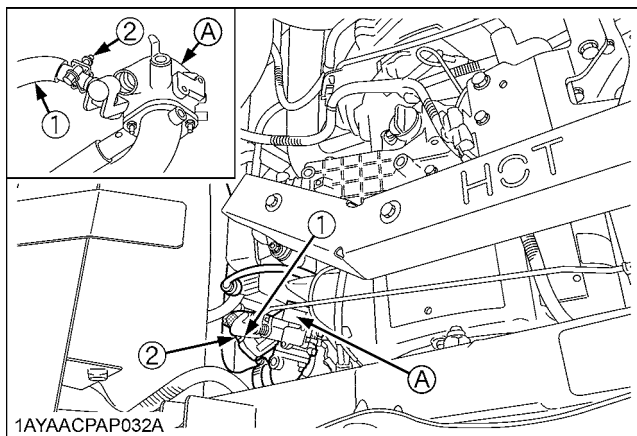

1C1YAACPAP032A

- (1) Fuel line (Fuel tank → Throttle body)  
 (2) Hose clamp  
 (A) Throttle body

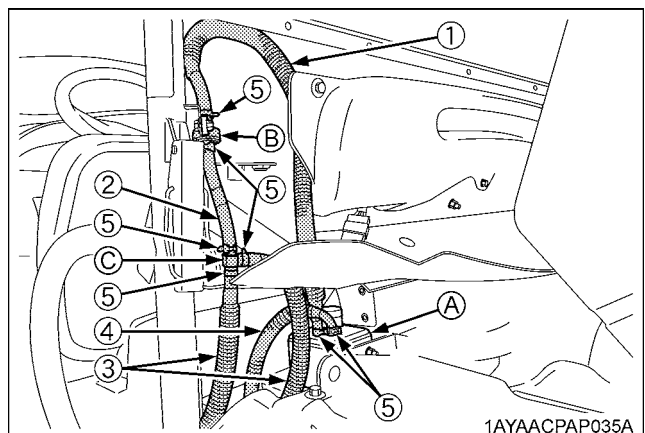

1D1YAACPAP035A

- (1) Fuel line (One way valve → Carbon canister)  
 (2) Fuel line (Three way connector → One way valve)  
 (3) Fuel line (Fuel tank → Three way connector)  
 (4) Fuel line (Carbon canister → Throttle body)  
 (5) Hose clamp  
 (A) Carbon canister  
 (B) One way valve  
 (C) Three way connector

### ■ Checking Carbon Canister Air Filter

Check the carbon canister air filter every 100 hours of operation. (more often under extremely dusty or dirty conditions.)

#### ⚠ CAUTION

To avoid personal injury:

- Stop the engine, set the parking brake and remove the key.

1. Raise the cargo bed, and push the safety support into the latch slot to lock.
2. Remove the cover and remove the carbon canister air filter.

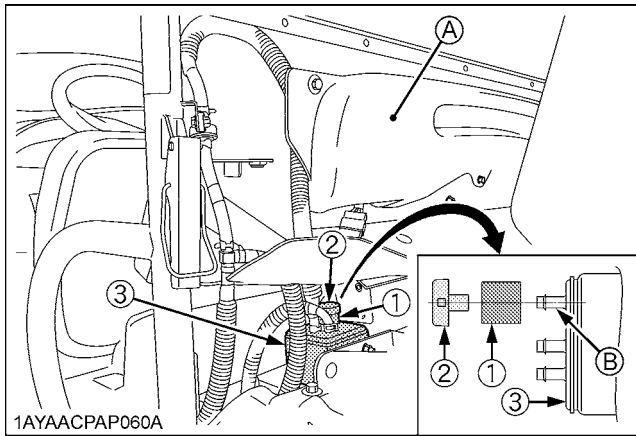

(1) Canister air filter (A) Intake air duct  
 (2) Cover (B) Air port  
 (3) Carbon canister

3. Check to see if the carbon canister air filter is worn out, damaged or dirty.
4. If the air filter is dirty, wash the air filter in warm water with detergent. Then rinse the air filter thoroughly until all traces of detergent are eliminated. Squeeze out excess water. (do not wring.) Allow the air filter to air dry. Do not use high pressure air to clean filter.
5. If the air filter is worn out, damaged or too dirty to wash clean, replace it with a new one.
6. Reinstall the carbon canister air filter and secure it with the cover.

#### NOTE :

- Operating in dusty condition may require more frequent maintenance than above.

### ■ Checking Battery Condition

#### ⚠ DANGER

To avoid the possibility of battery explosion:

For the refillable type battery, follow the instructions below.

- Do not use or charge the refillable type battery if the fluid level is below the LOWER (lower limit level) mark. Otherwise, the battery component parts may prematurely deteriorate, which may shorten the battery's service life or cause an explosion. Check the fluid level regularly and add distilled water as required so that the fluid level is between the UPPER and LOWER levels.

#### ⚠ CAUTION

To avoid personal injury:

- Never remove the vent caps while the engine is running.
- Keep electrolyte away from eyes, hands and clothes. If you are splattered with it, wash it away completely with water immediately and get medical attention.
- Wear eye protection and rubber gloves when working around the battery.

The factory-installed battery is non-refillable type. If the battery is weak, charge the battery or replace it with new one.

#### IMPORTANT :

- Mishandling the battery shortens the service life and adds to maintenance costs.  
 The original battery is maintenance free, but needs some servicing.  
 If the battery is weak, the engine will be difficult to start and the lights will be dim. It is important to check the battery periodically.
- When exchanging an old battery for new one, use battery of equal specification in table below.

| Battery TYPE | Volts (V) | Capacity at 20 hrs (A.H.) | Reserve Capacity (min) | Cold Cranking Amps |
|--------------|-----------|---------------------------|------------------------|--------------------|
| U1L-10       | 12        | 25                        | 22                     | 300                |

### ◆ Battery Charging



## CAUTION

To avoid personal injury:

- When the battery is being activated, hydrogen and oxygen gases in the battery are extremely explosive. Keep open sparks and flames away from the battery at all times, especially when charging the battery.
- When disconnecting the cable from the battery, start with the negative terminal first. When connecting the cable to the battery, start with the positive terminal first.
- Never check battery charge by placing a metal object across the posts. Use a voltmeter or hydrometer.

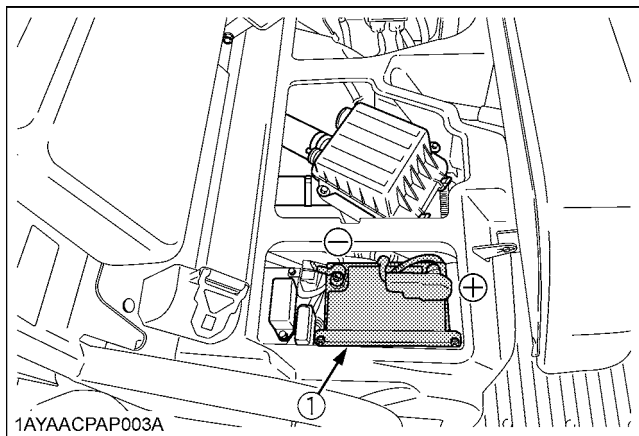

(1) Battery

1. To slow charge the battery, connect the battery positive terminal to the charger positive terminal and the negative to the negative, then charge for at least 1 hour at 6 to 10 amperes.
2. A boost charge is only for emergencies. It will partially charge the battery at a high rate and in a short time. When using a boost-charged battery, it is necessary to recharge the battery as early as possible. Failure to do this will shorten the battery's service life.

### ◆ Battery Replacing

1. Park the vehicle on a flat surface.
2. Apply the parking brake, stop the engine and remove the key.
3. Raise the seat.
4. Disconnect the cables from the negative terminal first, and then from the positive terminal.
5. Loosen the two nuts of the battery holder, take the rods out of the two elongated holes and remove the battery holder.

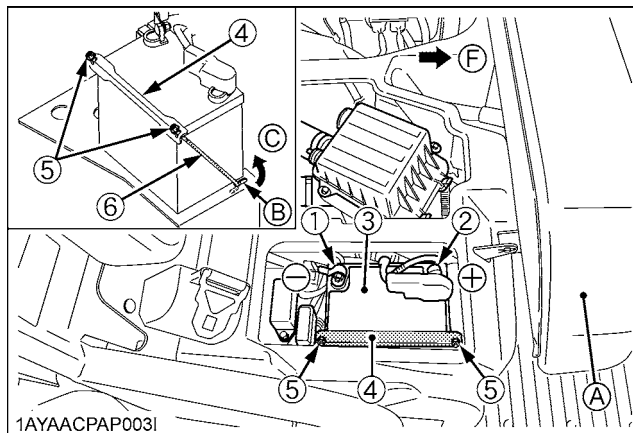

- |                    |                    |
|--------------------|--------------------|
| (1) Negative cable | (A) Seat           |
| (2) Positive cable | (B) Elongated hole |
| (3) Battery        | (C) "TAKE OUT"     |
| (4) Battery holder | (F) "FRONT"        |
| (5) Nut            |                    |
| (6) Rod            |                    |

6. Lift the battery from the vehicle, and install a new battery into the vehicle with the negative terminal positioned toward the rear of vehicle.
7. Install the battery holder to the vehicle with the two nuts in place, and tighten these nuts securely.
8. Connect the cable to the positive terminal first, and tighten it securely. Then connect the cable to the negative terminal, and tighten it securely.
9. Close the seat.

### ◆ Direction for Storage

1. When storing the vehicle for a long period, remove the battery from vehicle, adjust the electrolyte to the proper level (refillable type only) and store in a dry place out of direct sunlight.
2. The battery self-discharges while it is stored. Recharge it once every 3 months in hot seasons and once every 6 months in cold seasons.

## ■ Adjusting Toe-in

|               |                            |
|---------------|----------------------------|
| Proper toe-in | 0 to 20 mm (0 to 0.79 in.) |
|---------------|----------------------------|

1. Park vehicle on a flat place.
2. Turn steering wheel so front wheels are in the straight ahead position.
3. Lock the park brake and stop the engine.
4. Measure distance between tire beads at front of tire, at hub height.
5. Measure distance between tire beads at rear of tire, at hub height.
6. Front distance should be shorter than rear distance. If not, adjust tie rod length.

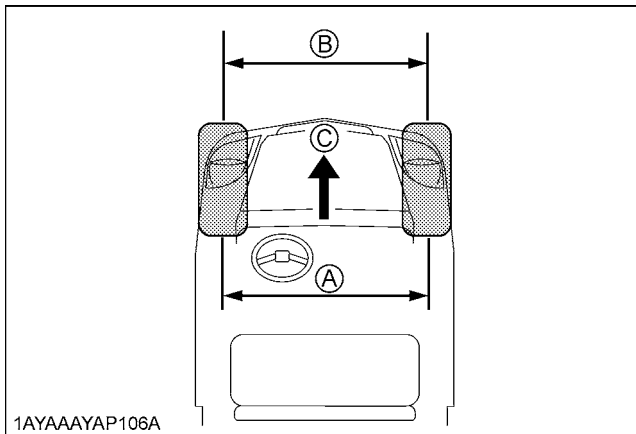

- (A) Wheel - to - wheel distance at rear  
 (B) Wheel - to - wheel distance at front  
 (C) "FRONT"

### ◆ Adjusting procedures

1. Loosen the lock nut and turn the tie rod to adjust the rod length until the proper toe-in measurement is obtained.
2. Retighten the lock nut.

#### NOTE :

- Tightening torque:  
 74.0 to 84.0 N-m  
 (7.6 to 8.5 kgf-m)  
 (55 to 61 lbf-ft)

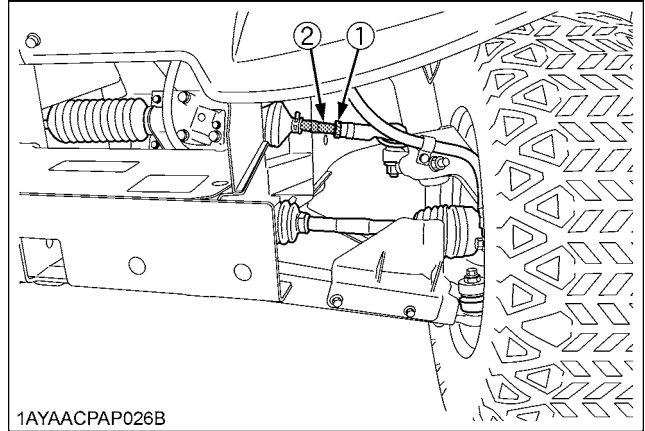

- (1) Lock nuts  
 (2) Tie-rod

#### IMPORTANT :

- Keep the length of the left and right tie-rod equal.



## ■ Cleaning Spark Arrester



### CAUTION

To avoid personal injury:

- After operating the engine, do not touch the muffler, exhaust pipe, or spark arrester until they have had sufficient time to cool.

This screen type spark arrester was examined, tested, and qualified in accordance with the USDA Forest Service Standard 5100-1c.

### ◆ Maintenance and cleanout procedure

The screen type spark arrester should be removed, cleaned, and inspected after every 100 hours of use.

1. The spark arrester is installed to the muffler with bolts.
2. Loosen the bolts and remove the spark arrester.
3. Shake particles off the screen and lightly clean the screen with a wire brush. Soak in solvent and clean with a wire brush again if necessary.
4. If any breakage is found in the screen or weldment, replace the assembly with a new one.
5. Reinstall the spark arrester to the muffler and tighten the bolts.

### IMPORTANT :

- USDA approval requires clearance between spark arrester sleeve and exhaust pipe to be no larger than 0.023" (0.584 mm).

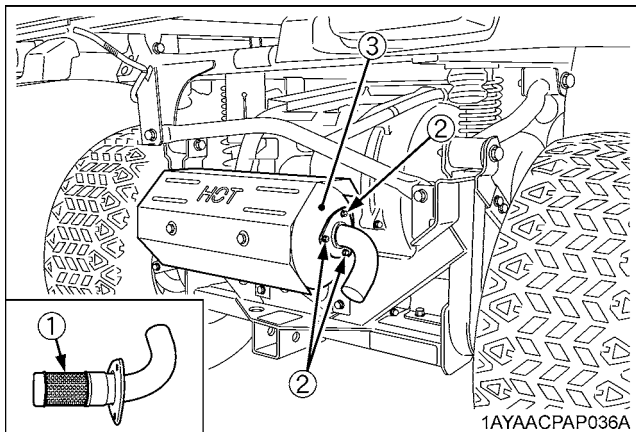

- (1) Spark arrester  
(2) Bolt  
(3) Muffler

## EVERY 200 HOURS

### ■ Adjusting Parking Brake Lever

The parking brake should be adjusted when the parking brake lever reaches 8 to 12 notches and will not hold the vehicle in place.

Consult your local KUBOTA dealer.

### ◆ Adjusting procedure

1. Park the vehicle on a firm, flat and level surface, and shut off the engine and remove the key.
2. Release the parking brake.
3. Loosen the lock nut, and adjust the cable wire length.
4. Pull the parking brake lever one notch, and make sure the vehicle does not roll easily by hand.
5. Release the parking brake, and make sure the vehicle rolls easily by hand.
6. Tighten the lock nut.

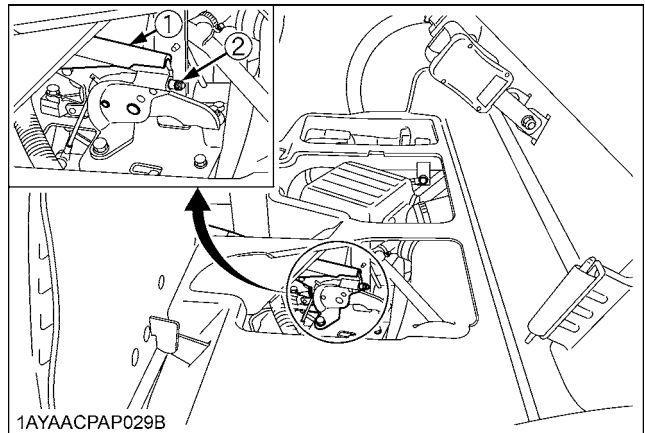

- (1) Parking brake lever  
(2) Lock nut

### ■ Replacing Engine Oil Filter

#### CAUTION

To avoid personal injury:

- Be sure to stop the engine before changing the oil filter cartridge.
- Allow engine to cool down sufficiently, oil can be hot and can burn.

1. Park the vehicle on a flat surface and raise the cargo bed. Shut off the engine and remove the key.
2. Remove the oil filter.
3. Put a film of clean engine oil on the rubber seal of the new filter.
4. Tighten the filter quickly until it contacts the mounting surface.  
Tighten filter by hand an additional 1/2 turn only.
5. After the new filter has been replaced, the engine oil normally decreases a little. Make sure that the engine oil does not leak through the seal and be sure to check the oil level on the dipstick. Then, replenish the engine oil up to the prescribed level.

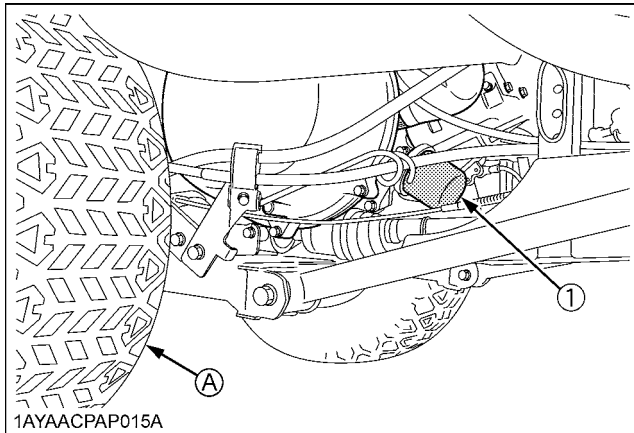

(1) Engine oil filter (A) Right rear tire

#### IMPORTANT :

- To prevent serious damage to the engine, use only a KUBOTA genuine filter.

### ■ Checking and Cleaning Engine Cooling Air Inlet and Engine Cooling Fin

#### CAUTION

To avoid personal injury:

- Park the vehicle on a firm and level surface.
- Stop the engine, remove the key and apply the parking brake.
- Allow the engine to cool down sufficiently when checking and cleaning.

#### IMPORTANT :

- Engine cooling air inlet and engine cooling fin must be clear of debris to prevent the engine from overheating.
1. Raise the cargo bed, and push the safety support into the latch slot to lock.
  2. Check the engine cooling air inlet for dirt and debris, and wash it clean with water.

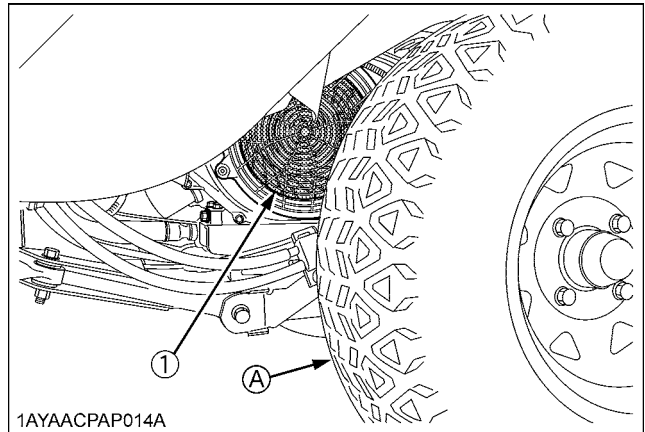

(1) Engine cooling air inlet (A) Left rear tire

3. Check the engine cooling fin for dirt and debris, and clear them with air pressure (not to exceed 205 kPa (2.1 kgf/cm<sup>2</sup>, 30 psi)).

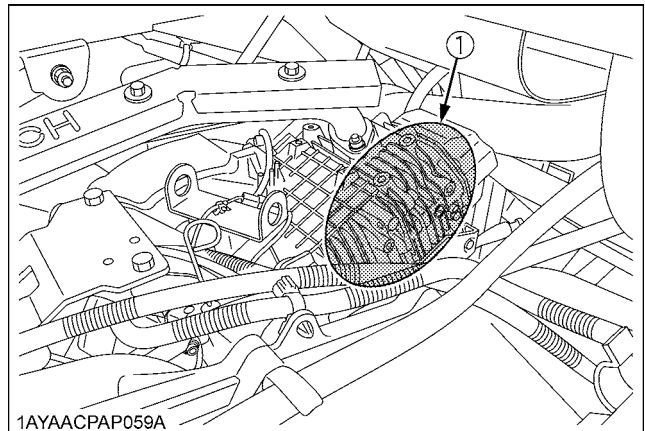

(1) Engine cooling fin

### ■ Checking Brake Pedal

#### ⚠ CAUTION

To avoid personal injury:

- Stop the engine and chock the wheels before checking brake pedal.
- If movement is outside of the specifications, contact your local KUBOTA Dealer for adjusting the brake.

#### ◆ Checking the brake pedal free travel

|                                |  |
|--------------------------------|--|
| Proper brake pedal free travel | 7 to 14 mm (0.3 to 0.6 in.) on the pedal |
|--------------------------------|--|

1. Release the parking brake.
2. Slightly depress the brake pedal and measure free travel at the top of the pedal stroke.
3. If brake pedal free travel is outside of the specifications, contact your local KUBOTA Dealer for adjusting the brake.

#### ◆ Checking the brake pedal stroke

|              |   |
|--------------|---|
| Pedal stroke | Less than 65 mm (2.56 in.) on the pedal |
|--------------|---|

1. Release the parking brake.
2. Step on the pedal and measure the pedal stroke.
3. If brake pedal stroke is outside of the specifications, contact your local KUBOTA Dealer for adjusting the brake.

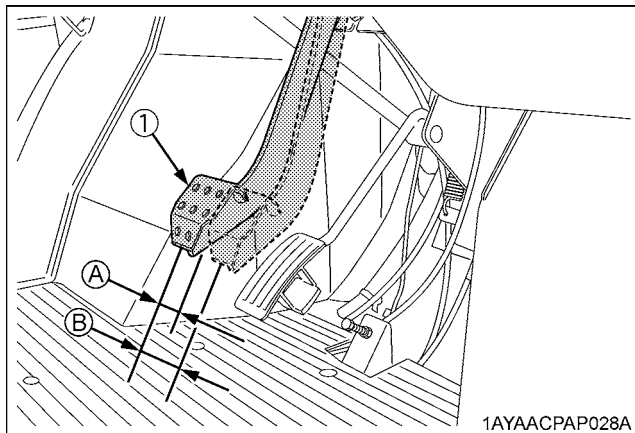

(1) Brake pedal

(A) "FREE TRAVEL"  
(B) "PEDAL STROKE"

### ■ Checking Brake Hose and Pipe

1. Check to see that brake hose and pipe are not swollen, hardened or cracked.
2. Check the brake hose and pipe joints for oil leaks.
3. If there is any abnormality, consult your local KUBOTA Dealer for this service.

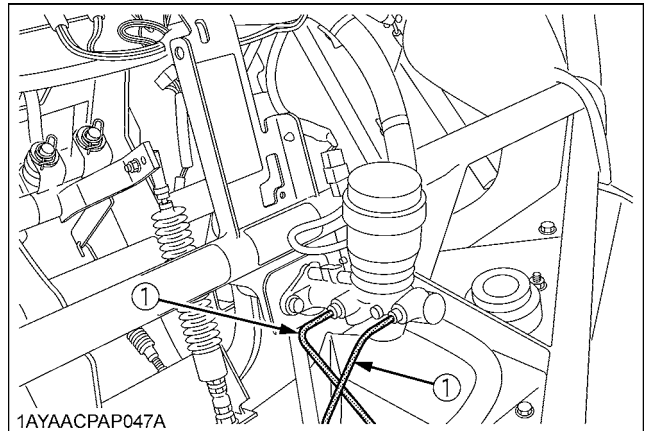

(1) Brake pipe

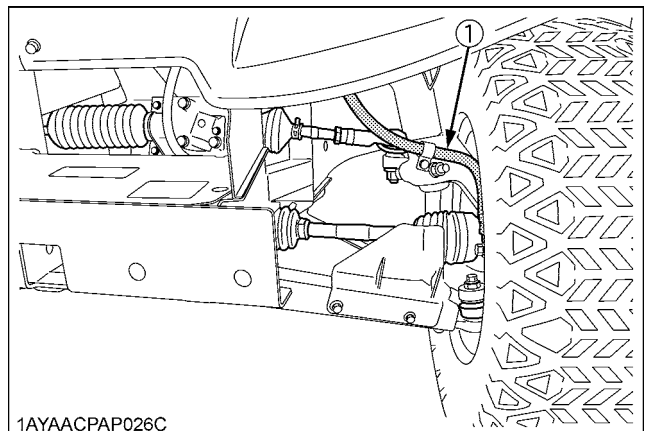

(1) Brake hose (Front)

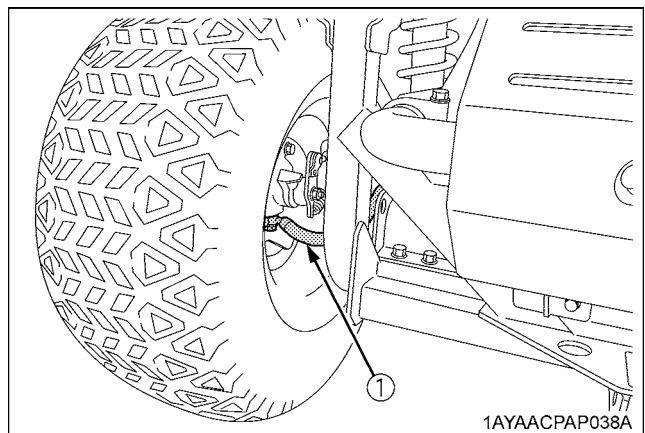

(1) Brake hose (Rear)

### ■ Checking Brake Light Switch

1. Park the vehicle on a flat surface.
2. Step on the brake pedal to check if the brake light comes on.
3. If it does not, check the bulb or brake light switch.

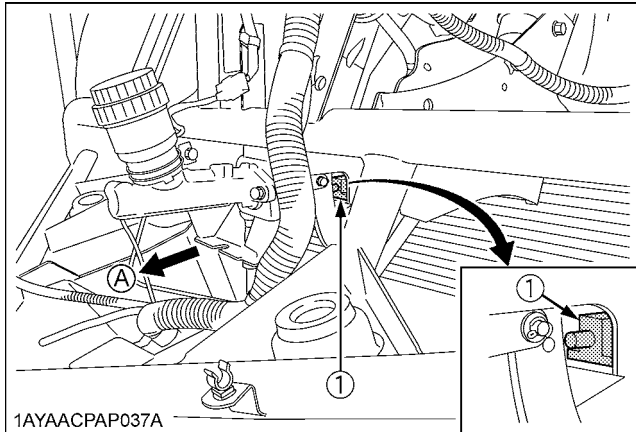

(1) Brake light switch

(A) "FRONT"

### ■ Checking Engine Intake Air Line

1. Check to see if the duct, hoses and hose clamps are tight and not damaged.
2. If any of the duct, hoses and clamps is found worn out or damaged, replace or repair it at once.

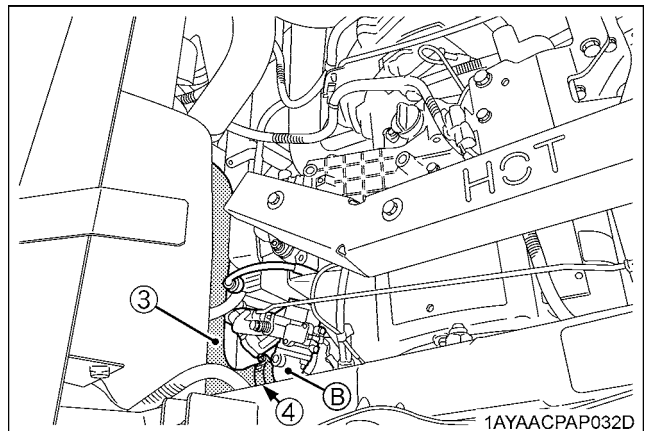
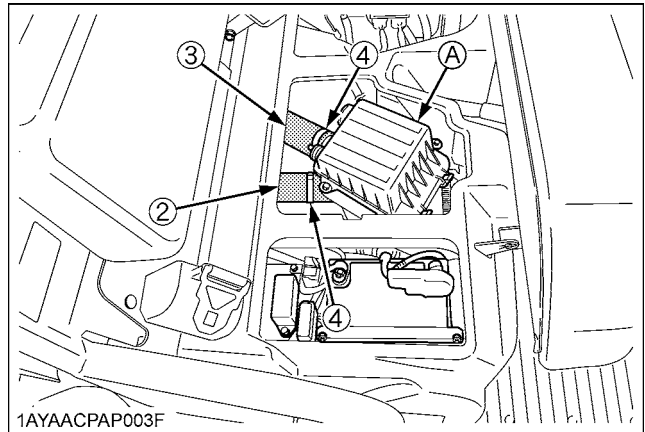
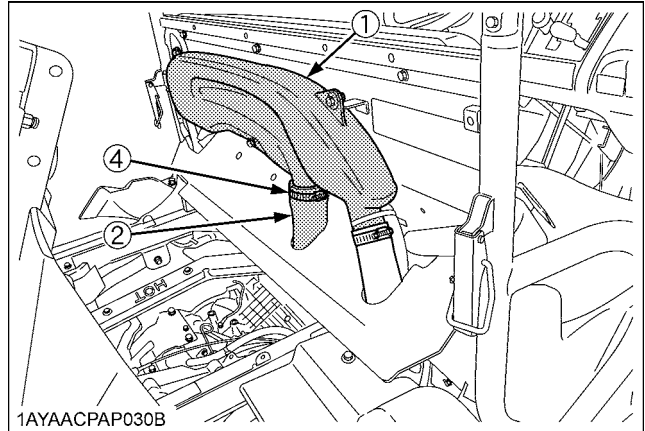

- (1) Intake air duct
- (2) Hose (Intake air duct → Engine air cleaner)
- (3) Hose (Air cleaner → Throttle elbow)
- (4) Hose clamp
- (A) Engine air cleaner
- (B) Throttle elbow

### ■ Checking CVT Intake Air Line

1. Check to see if the duct, hoses and hose clamps are tight and not damaged.
2. If any of the duct, hoses and hose clamps is found worn out or damaged, replace or repair it at once.

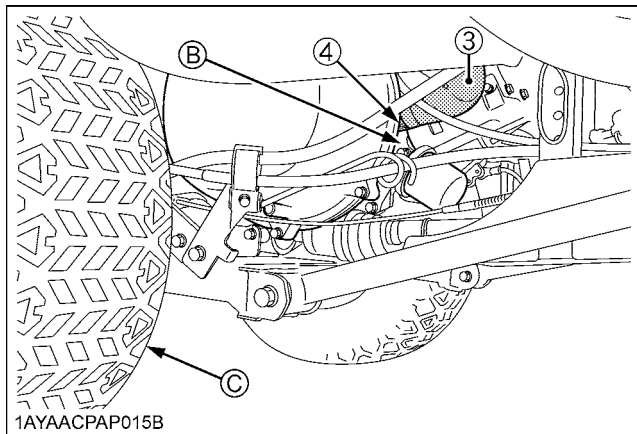
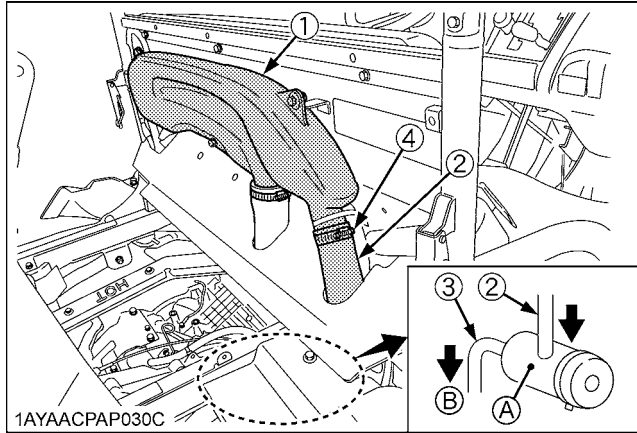

- (1) Intake air duct
- (2) Hose (Intake air duct → CVT air cleaner)
- (3) Hose (CVT air cleaner → CVT)
- (4) Hose clamp
- (A) CVT air cleaner
- (B) CVT
- (C) Right rear tire

### ■ Checking CVT Belt

Consult your local KUBOTA Dealer for this service.

## EVERY 300 HOURS

### ■ Checking Tire

1. Check to see if tires are not damaged.
2. If the tires are cracked, bulged, or cut, or they are worn out, replace or repair them at once.

### ◆ Tire Tread Depth

Always replace the tires when the tread depth is worn to minimum allowable.

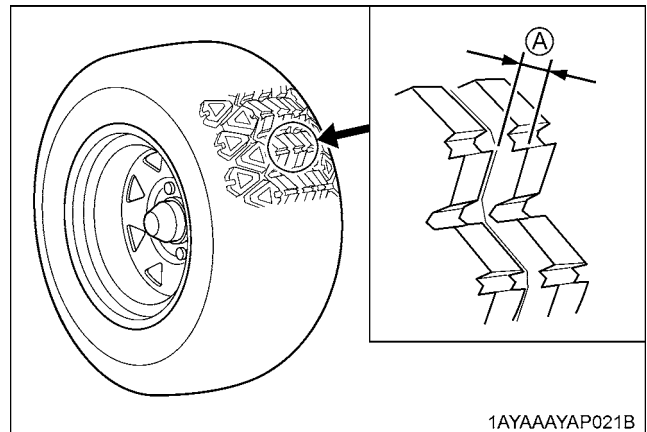

(A) 3 mm (0.12 in.)

### ■ Adjusting Engine Valve Clearance

If you do not have the proper tools and/or are not mechanically proficient, consult your local KUBOTA Dealer for this service.

## EVERY 400 HOURS

### ■ Changing Transmission Oil



#### CAUTION

To avoid personal injury:

- Allow engine to cool down sufficiently, oil can be hot and can burn.

1. Park the vehicle on a flat surface, and apply parking brake then raise the cargo bed. Shut off the engine and remove the key.
2. To drain the used oil, remove the drain plug at the bottom of the transmission case and drain the oil completely into the oil pan.
3. Check the rubber washer on the drain plug. Replace it if missing or in poor condition.
4. After draining, reinstall the drain plug.
5. Fill with the new KUBOTA SUPER UDT fluid up to the upper notch on the dipstick.  
(See "LUBRICANTS AND FUEL" in "MAINTENANCE" section.)
6. After running the engine for a few minutes, stop the engine and check the oil level again; add oil to prescribed level.

|              |                       |
|--------------|-----------------------|
| Oil Capacity | 5.4 L (1.4 U.S.gals.) |
|--------------|-----------------------|

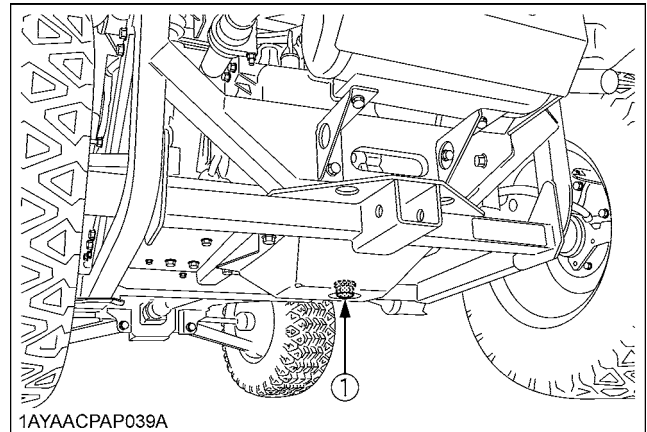

(1) Drain plug

#### IMPORTANT :

- Do not operate the vehicle immediately after changing the transmission fluid.  
Run the engine at medium speed for a few minutes to prevent damage to the transmission.

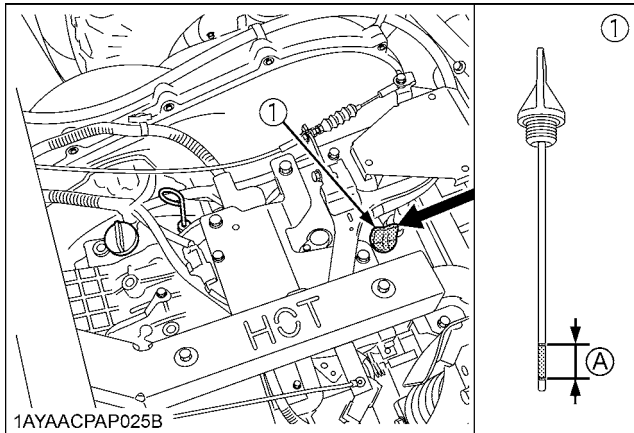

(1) Dipstick (A) Oil level is acceptable within this range.

**Changing Front Axle Case Oil**

1. Park the vehicle on a firm, flat and level surface.
2. To drain the used oil, remove the drain and filling plugs at the front axle case and drain the oil completely into the oil pan.
3. After draining, reinstall the drain plug.
4. Fill with the new oil up to the upper notch on the dipstick.  
(See "LUBRICANTS AND FUEL" in "MAINTENANCE" section.)
5. After filling, reinstall the filling plug.

|              |                        |
|--------------|------------------------|
| Oil capacity | 0.21 L (0.22 U.S.qts.) |
|--------------|------------------------|

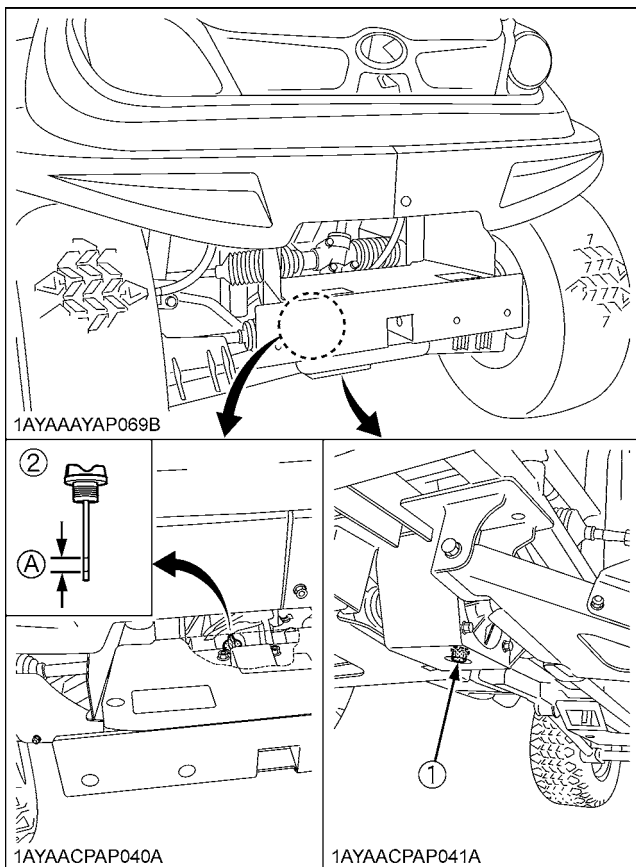

(1) Drain plug  
 (2) Filling plug with dipstick  
 (A) Oil level is acceptable within this range

**EVERY 500 HOURS**

**Cleaning Engine Combustion Chamber**

If you do not have the proper tools and/or are not mechanically proficient, consult your local KUBOTA Dealer for this service.

**EVERY 1 YEAR**

**Replacing Engine Air Cleaner Element**

(See "Cleaning Engine Air Cleaner Element" in "EVERY 100 HOURS" in "PERIODIC SERVICE" section.)

**Replacing CVT Air Cleaner Element**

(See "Cleaning CVT Air Cleaner Element" in "EVERY 100 HOURS" in "PERIODIC SERVICE" section.)

## EVERY 2 YEARS

### ■ Changing Brake Fluid

Consult your local KUBOTA Dealer for this service.  
(See "Checking Brake Fluid Level" in "DAILY CHECK" in "PERIODIC SERVICE" section.)

### ■ Replacing Fuel Hose

Consult your local KUBOTA Dealer for this service.

### ■ Replacing Brake Master Cylinder (Inner Parts)

Consult your local KUBOTA Dealer for this service.

### ■ Replacing Engine Intake Air Line

Consult your local KUBOTA Dealer for this service.

### ■ Replacing CVT Intake Air Line

Consult your local KUBOTA Dealer for this service.

### ■ Replacing Engine Breather Hose

Consult your local KUBOTA Dealer for this service.

## EVERY 4 YEARS

### ■ Replacing Brake Hose

Consult your local KUBOTA Dealer for this service.

## SERVICE AS REQUIRED

### ■ Checking Brake Pad



### CAUTION

To avoid personal injury:

- The machine can fall or slip from an unsafe device or supports.
- Use a safe lifting device rated for the load to be lifted.
- Lower the vehicle onto jack stands and block the wheels before servicing. (See "JACK-UP POINT" in "PERIODIC SERVICE" section.)

1. Park the vehicle on a firm, flat and level surface.
2. Raise the vehicle with a safe device and lower onto the jack or other stable supports. Block the wheels remaining on the ground to prevent the vehicle from moving.
3. Remove the wheel bolts and the tires.

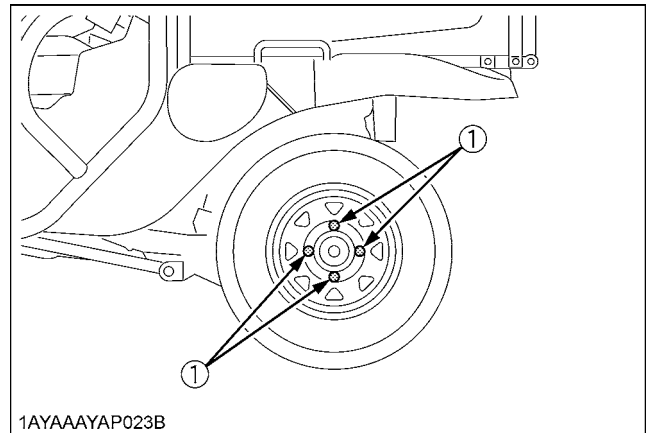

1AYAAAYAP023B

(1) Wheel bolts



## 4. Check the brake pads for wear or damage.

Check the pad's thickness:

Minimum thickness (t) should be 1mm (3/64 inch). If below this or pad material is damaged, contact your local Kubota Dealer.

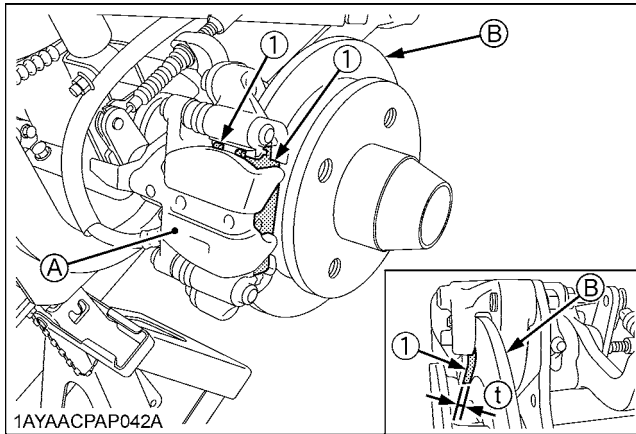

(1) Brake pad

(A) Disk brake assy

(B) Brake disk

(t) Thickness

5. Reinstall the tires with the valve stem to the outside.
6. Tighten the wheel bolts evenly in alternating sequence until snug.
7. Repeat the same procedure for remaining three tires.
8. Lower the vehicle completely to the ground.
9. Tighten the wheel bolts from 108.4 to 121.9 N-m (80 to 90 lbf-ft).

### ■ Adjusting Parking Brake

For proper adjusting of the parking brake, consult your local KUBOTA Dealer.

### ■ Adjusting Alternator Drive Belt Tension

For proper adjusting of the alternator drive belt, consult your local KUBOTA Dealer.

### ■ Replacing Fuse

The vehicle electrical system is protected from potential damage by fuses.

A blown fuse indicates that there is an overload or short somewhere in the electrical system.

If any of the fuses should blow, replace with a new one of the same capacity.

#### IMPORTANT :

- Before replacing a blown fuse, determine why the fuse blew and make any necessary repairs. Failure to follow this procedure may result in serious damage to the vehicle electrical system. Consult your local KUBOTA Dealer for specific information dealing with electrical problems.

#### ◆ Replacement procedure

1. Disconnect the negative cable of the battery.
2. Remove the cover and the fuse box cover.
3. Pull out the blown fuse using FUSE PULLER in the fuse box.
4. Insert a new fuse into the fuse box.
5. Install the fuse box cover.
6. Connect the negative battery cable.

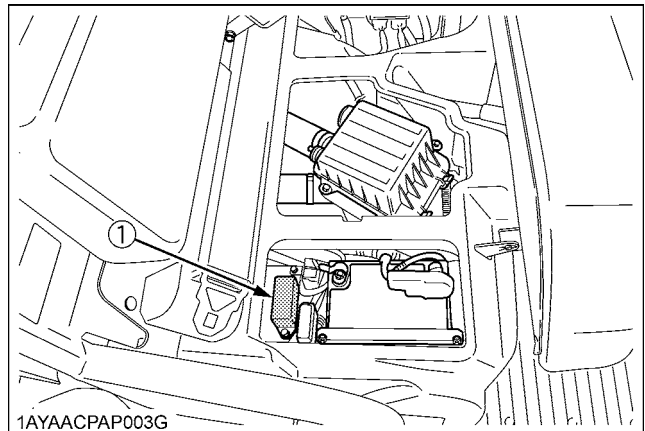

(1) Fuse box

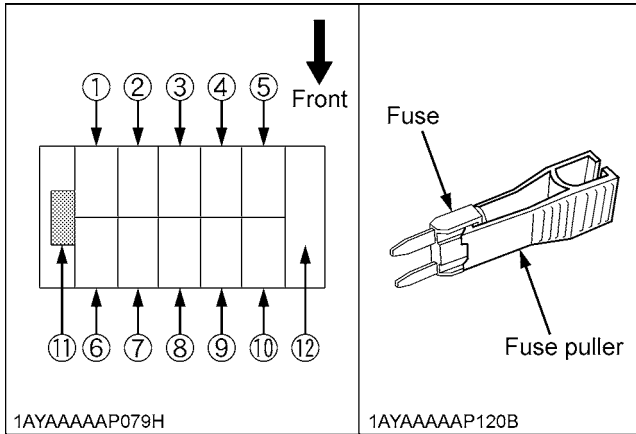

### ■ Replacing Slow-Blow Fuses

The slow-blow fuses are intended to protect the electrical cabling. If any of them have blown out, be sure to pinpoint the cause. Never use any substitute, use only a KUBOTA genuine part.

#### ◆ Replacement procedure

1. Disconnect the negative cable of the battery.
2. Remove the cover and the slow-blow fuse box cover.
3. Pull out the slow-blow fuse.
4. Insert a new slow-blow fuse into the slow-blow fuse box.
5. Install the slow-blow fuse box cover.
6. Connect the negative battery cable.

#### ◆ Protected circuit

| Fuse No. | Capacity (A) | Protected circuit (OLD)                       |
|----------|--------------|---|
| 1        | 15           | Head lamp, Tail lamp, Panel                   |
| 2        | 10           | Eng. control, Fuel pump                       |
| 3        | 5            | Starter                                       |
| 4        | ---          | ---   |
| 5        | 15           | (Hazard)                                      |
| 6        | 10           | Regulator, (Work light relay), (AUX (KEY ON)) |
| 7        | 5            | Panel   |
| 8        | 10           | 12V DC output                                 |
| 9        | 15           | Brake lamp, Horn                              |
| 10       | 15           | (Work light)                                  |
| 11       | ---          | Fuse puller                                   |
| 12       | 5, 10, 15    | Spare   |

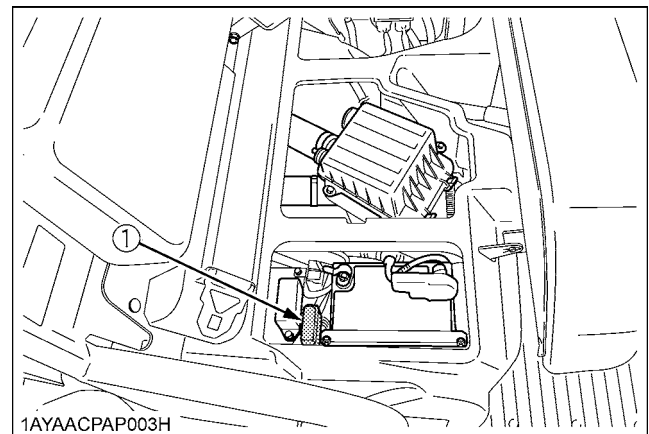

(1) Slow-blow fuse box

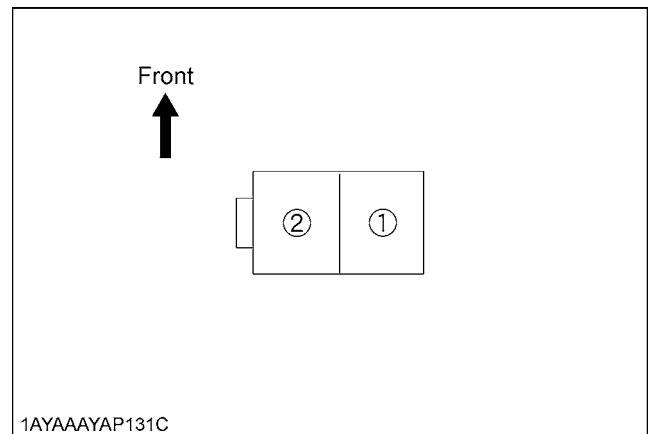

#### ◆ Protected circuit

| Fuse No. | Capacity (A)        | Protected circuit |
|----------|---------------------|-------------------|
| 1        | Slow-blow fuse (30) | Key switch        |
| 2        | Slow-blow fuse (50) | Regulator         |

**■ Replacing Light Bulb**

1. Head lights  
Take the bulb out of the light body and replace it with a new one.
2. Other lights  
Detach the lens and replace the bulb.

| Light  | Capacity           |
|--|--------------------|
| Head lights  | 27 W               |
| Tail light   | 5 W                |
| Brake light  | 21 W               |
| Easy Checker(TM)                                     | 3.8 W (14V, 0.27A) |
| Engine diagnostic light [LED]<br>of Easy Checker(TM) | 0.25 W (14V, 18mA) |
| Instrument panel light                               | 3.8 W (14V, 0.27A) |

# STORAGE



## CAUTION

To avoid personal injury:

- Do not clean the vehicle with engine running.
- To avoid the danger of exhaust fume poisoning, do not operate the engine in a closed building without proper ventilation.
- When storing, remove the key from the key switch to avoid unauthorized persons from operating the vehicle and getting injured.

## VEHICLE STORAGE

If you intend to store your vehicle for an extended period of time, follow the procedures outlined below.

These procedures will insure that the vehicle is ready to operate with minimum preparation when it is removed from storage.

1. Check the bolts and nuts for looseness, and tighten if necessary.
2. Apply grease to vehicle areas where bare metal will rust also to pivot areas.
3. Unload from cargo bed.
4. Inflate the tires to a pressure a little higher than usual.
5. Change the engine oil and run the engine to circulate oil throughout the engine block and internal moving parts for about 5 minutes.
6. With all implements lowered to the ground, coat any exposed hydraulic cylinder piston rods with grease (if equipped).
7. Remove the battery from the vehicle. Store the battery following the battery storage procedures.  
(See "Checking Battery Condition" in "EVERY 100 HOURS" in "PERIODIC SERVICE" section.)
8. Keep the vehicle in a dry place where the vehicle is sheltered from the elements. Cover the vehicle.
9. Store the vehicle indoors in a dry area that is protected from sunlight and excessive heat. If the vehicle must be stored outdoors, cover it with a waterproof tarpaulin.  
Put boards under the tires to keep dampness away from tire.  
Keep the tires out of direct sunlight and extreme heat.

### IMPORTANT :

- When washing the vehicle, be sure to stop the engine. Allow sufficient time for the engine to cool before washing.
- Do not wash with a high-pressure car-washing machine.
- Cover the vehicle after the muffler and the engine have cooled down.

## REMOVING THE VEHICLE FROM STORAGE

1. Check the tire air pressure and inflate the tires if they are low.
2. Install the battery. Before installing the battery, be sure it is fully charged.
3. Check all fluid levels (engine oil, transmission oil and any attached implements).
4. Check the spark plug gap. Install and tighten plugs to the specified torque.
5. Start the engine. Observe all gauges. If all gauges are functioning properly and reading normal, move the vehicle outside. Once outside, park the vehicle and let the engine idle for at least 5 minutes. Shut the engine off and walk around vehicle and make a visual inspection looking for evidence of oil or water leaks.
6. With the engine fully warmed up, release the parking brake and test the brakes for proper adjustment as you move forward. Adjust the brakes as necessary.

# TROUBLESHOOTING

## ENGINE TROUBLESHOOTING

If something is wrong with the engine, refer to the table below for the cause and its corrective measure.

| Trouble  | Cause   | Countermeasure   |
|--|---|--|
| <b>Engine is difficult to start or will not start.</b>                 | ● The range shift lever not in the proper position.   | ● Make sure the range shift lever is in "NEUTRAL" position.            |
|  | ● Key switch is not in the proper position.   | ● Make sure key switch is in "ON" position.                            |
|  | ● No fuel.  | ● Replenish fuel.  |
|  | ● Improper or stale fuel.<br>(Fuel quality is poor.)  | ● Replace fuel and consult your KUBOTA Dealer.                         |
|  | ● Water or dirt in the fuel system.   | ● Replace fuel and consult your KUBOTA Dealer.                         |
|  | ● Fuel hose or fuel filter clogged or damaged.  | ● Clean or replace fuel lines, and consult your KUBOTA Dealer.         |
|  | ● Air cleaner is clogged.   | ● Clean or replace the air cleaner element.                            |
|  | ● Spark plug defective.   | ● Adjust the spark plug gap or replace the spark plug.                 |
|  |   | ● Check the spark plug wire connection.                                |
|  | ● Fuse is blown.  | ● Replace the fuse.  |
|  | ● Engine oil viscosity is wrong.  | ● Use oils of different viscosities, depending on ambient temperature. |
| ● Battery becomes weak and the engine does not turn over quick enough. | ● Clean battery cables and terminals.   |  |
|  | ● Charge the battery.   |  |
|  | ● In cold weather, always remove the battery from the engine, charge and store it indoors. Install it on the machine only when the machine is going to be used. |  |
| <b>Insufficient engine power.</b>                                      | ● Insufficient or dirty fuel.   | ● Check the fuel system.   |
|  | ● Air cleaner is clogged.   | ● Clean or replace the air cleaner element.                            |
|  | ● Spark plug defective.   | ● Adjust the spark plug gap or replace it.                             |
| <b>Engine stops suddenly.</b>  | ● Insufficient fuel.  | ● Refuel.  |

| Trouble   | Cause  | Countermeasure   |
|---|--|--|
| <b>Rough engine running.</b>                                | ● Spark plug defective.  | ● Adjust the spark plug gap or replace it.                       |
|   | ● High tension cord defective.   | ● Consult your KUBOTA Dealer.                                    |
|   | ● Ignition coil defective.   | ● Consult your KUBOTA Dealer.                                    |
|   | ● Fuel hose or fuel filter clogged or damaged.   | ● Clean or replace fuel lines, and consult your KUBOTA Dealer.   |
|   | ● Improper or stale fuel.<br>(Fuel quality is poor.)   | ● Replace fuel and consult your KUBOTA Dealer.                   |
|   | ● Air cleaner is clogged.  | ● Clean or replace the air cleaner element.                      |
| <b>Exhaust fumes are colored.<br/>(Black, Dark or Gray)</b> | ● Overload.  | ● Reduce load.   |
|   | ● Low grade fuel is used.  | ● Use specified fuel.  |
|   | ● Air cleaner is clogged.  | ● Clean or replace the air cleaner element.                      |
| <b>Exhaust fumes are colored.<br/>(White or Blue)</b>       | ● Excessive engine oil.  | ● Reduce to the specified oil level.                             |
|   | ● Piston ring is worn or stuck.  | ● Consult your KUBOTA Dealer.                                    |
| <b>Engine overheats</b>                                     | ● Engine cooling air inlet is clogged.   | ● Remove all trash.  |
|   | ● Engine cooling fin is dirty with debris accumulated.   | ● Clean engine cooling fin.                                      |
| <b>Engine diagnostic light comes on.</b>                    | ---  | ● Consult your KUBOTA Dealer.                                    |
| <b>Engine will not idle.</b>                                | ● Spark plug defective.  | ● Adjust the spark plug gap or replace it.                       |
|   | ● Faulty spark plug.   | ● Replace the spark plug.  |
|   | ● Incorrect idle adjustment  | ● Consult your KUBOTA Dealer.                                    |
|   | ● Throttle link and governor link are not put back in place, being caught with a stone, debris, etc. | ● Remove any debris from around throttle link and governor link. |

If you have any questions, consult your local KUBOTA Dealer.

## BATTERY TROUBLESHOOTING

| Trouble  | Cause  | Countermeasure                                | Preventive measure   |
|--|--|---|--|
| <b>Starter does not function.</b>  | ● Battery overused until lights are dim.                       | ● Charge battery sufficiently.                | ● Charge the battery properly.   |
|  | ● Battery has not been recharged.                              |   |  |
|  | ● Poor terminal connection.                                    | ● Clean the terminal and tighten securely.    | ● Keep the terminal clean and tight.<br>Apply grease and treat with anti-corrosives. |
|  | ● Battery life expired.  | ● Renew battery.                              |  |
| <b>From beginning starter does not function, and lights soon become dim.</b> | ● Insufficient charging.                                       | ● Charge battery sufficiently.                | ● Battery must be serviced properly before initial use.                              |
| <b>When viewed from top, the top of plates look whitish.</b>                 | ● Battery was used with an insufficient amount of electrolyte. | ● Add distilled water and charge the battery. | ● Regularly check the electrolyte level.   |
|  | ● Battery was used too much without recharging.                | ● Charge battery sufficiently.                | ● Charge the battery properly.   |
| <b>Recharging is impossible.</b>   | ● Battery life expired.  | ● Replace battery.                            |  |
| <b>Terminals are severely corroded and heat up.</b>                          | ● Poor terminal connection.                                    | ● Clean the terminal and tighten securely.    | ● Keep the terminal clean and tight.<br>Apply grease and treat with anti-corrosives. |
| <b>Battery electrolyte level drops rapidly.</b>                              | ● There is a crack or pin holes in the electrolytic cells.     | ● Replace battery.                            |  |
|  | ● Charging system trouble.                                     | ● Consult your local KUBOTA Dealer.           |  |

If you have any questions, consult your local KUBOTA Dealer.

## MACHINE TROUBLESHOOTING

| Trouble   | Cause   | Countermeasure  |
|---|---|---|
| <b>Machine operation is not smooth.</b>               | <ul style="list-style-type: none"> <li>● CVT belt life expired</li> </ul>     | <ul style="list-style-type: none"> <li>● Consult your KUBOTA Dealer.</li> </ul> |
| <b>Machine does not move while engine is running.</b> | <ul style="list-style-type: none"> <li>● Parking brake is on.</li> </ul>      | <ul style="list-style-type: none"> <li>● Release the parking brake.</li> </ul>  |
|   | <ul style="list-style-type: none"> <li>● CVT belt is broken.</li> </ul>       | <ul style="list-style-type: none"> <li>● Consult your KUBOTA Dealer.</li> </ul> |
| <b>Brakes not working correctly</b>                   | <ul style="list-style-type: none"> <li>● Brake fluid level is low.</li> </ul> | <ul style="list-style-type: none"> <li>● Check fluid level.</li> </ul>          |
|   | <ul style="list-style-type: none"> <li>● Air is in brake system.</li> </ul>   | <ul style="list-style-type: none"> <li>● Consult your KUBOTA Dealer.</li> </ul> |
|   | <ul style="list-style-type: none"> <li>● Brake pads are worn.</li> </ul>      | <ul style="list-style-type: none"> <li>● Consult your KUBOTA Dealer.</li> </ul> |
| <b>Brake noise</b>                                    | ---   | <ul style="list-style-type: none"> <li>● Consult your KUBOTA Dealer.</li> </ul> |

If you have any questions, consult your local KUBOTA Dealer.



# OPTIONS

Consult your local KUBOTA Dealer for further details.

- Backup Beeper
- Bed Liner
- Cab Heater (cab only)
- Camo Steel Cab
- Fabric Cover
- Front Accessory Box
- Front Guard (Silver)
- Front Heavy Load Strut
- Front Trailer Hitch & Pin (2")
- Front Work Light  
(for plastic canopy or no canopy, one or two)
- Modular Cab  
(W/ steel doors)
- Plastic Canopy (Black)
- Rear Net
- Rear Trailer Hitch & Pin (2")
- Rear Work Light\*  
(for plastic canopy or no canopy)
- Safety Windshield
- Snow Blade (62") require Heavy Duty Spring Kit
- Speedometer
- Strobe Light\*
- Turn Signal / Hazard Light Kit
- Warn 2.5CI
- Work Lights Kit\*  
(for metal canopy or cab, include two lights for front or rear)

**IMPORTANT :**

- Do not use electrical options (\* marked) at idling speed for many hours.

# ENGINE EMISSION RELATED INFORMATION

◆ **The engine conforms to U.S. EPA and California emission regulations for off-road small SI engines.**

- Emission compliance period: 500 HOURS
- CARB emissions durability period: EXTENDED

◆ **Exhaust Emission Control System**

- Throttle Body Injection, Electronic Control Module, Three Way Catalyst

# Kubota

- U.S.A. : **KUBOTA TRACTOR CORPORATION**  
3401 Del Amo Blvd., Torrance, CA 90503, U.S.A.  
Telephone : (310)370-3370
- Western Division : 1175 S. Guild Av., Lodi, CA 95240  
Telephone : (209)334-9910
- Central Division : 14855 FAA Blvd., Fort Worth, TX 76155  
Telephone : (817)571-0900
- Northern Division : 6300 at One Kubota Way, Groveport, OH 43125  
Telephone : (614)835-1100
- Southeast Division : 1025 Northbrook Parkway, Suwanee, GA 30024  
Telephone : (770)995-8855
- Canada : **KUBOTA CANADA LTD.**  
5900 14th Avenue, Markham, Ontario, L3S 4K4, Canada  
Telephone : (905)294-7477
- France : **KUBOTA EUROPE S.A.S**  
19-25, Rue Jules Vercey, Z.I. BP88, 95101 Argenteuil Cedex, France  
Telephone : (33)1-3426-3434
- Italy : **KUBOTA EUROPE S.A.S Italy Branch**  
Via Grandi, 29 20068 Peschiera Borrome (MI) Italy  
Telephone : (39)02-51650377
- Germany : **KUBOTA (DEUTSCHLAND) GmbH**  
Senefelder Str. 3-5 63110 Rodgau /Nieder-Roden, Germany  
Telephone : (49)6106-873-0
- U.K. : **KUBOTA (U.K.) LTD.**  
Dormer Road, Thame, Oxfordshire, OX9 3UN, U.K.  
Telephone : (44)1844-214500
- Spain : **KUBOTA ESPAÑA S.A.**  
Avenida Recomba No.5, Poligono Industrial la Laguna, Leganes, 28914 (Madrid) Spain  
Telephone : (34)91-508-6442
- Australia : **KUBOTA TRACTOR AUSTRALIA PTY LTD.**  
25-29 Permas Way, Truganina, VIC 3029, Australia  
Telephone : (61)-3-9394-4400
- Malaysia : **SIME KUBOTA SDN. BHD.**  
No.3 Jalan Sepadu 25/123 Taman Perindustrian Axis,  
Seksyen 25, 40400 Shah Alam, Selangor Darul Ehsan Malasia  
Telephone : (60)3-736-1388
- Philippines: **KUBOTA PHILIPPINES, INC.**  
155 Panay Avenue, South Triangle Homes, 1103 Quezon City, Philippines  
Telephone : (63)2-9201071
- Taiwan : **SHIN TAIWAN AGRICULTURAL MACHINERY CO., LTD.**  
16, Fengping 2nd Rd, Taliuo Shiang Kaohsiung 83107, Taiwan R.O.C.  
Telephone : (886)7-702-2333
- Indonesia : **P.T. KUBOTA INDONESIA**  
JALAN. Setyabudi 279, Semarang, Indonesia  
Telephone : (62)-24-7472849
- Thailand : **SIAM KUBOTA CORPORATION CO., LTD.**  
101/19-24 Moo 20, Navanakorn Industrial Estate, Tambon Khlongnueng, Amphur Khlongluang,  
Pathumthani 12120, THAILAND  
Telephone : (66)2-909-0300
- Korea : **KUBOTA KOREA CO., LTD.**  
106-24 Mongsan-Ri, Mankyung-Up, Kimje-City, Chonrapuk-Do, KOREA  
Telephone : (82)-63-544-5822
- India : **KUBOTA AGRICULTURAL MACHINERY INDIA PVT. LTD.**  
Regus, Level 2 Altius, Olympia Tech Park, No.1 SIDCO Industrial Estate, Guindy, Chennai 600032, TN, India  
Telephone : (91)-44-4299-4237
- Vietnam : **KUBOTA VIETNAM CO., LTD.**  
Lot B-3A2-CN, My Phuoc 3 Industrial Park, Ben Cat District, Binh Duong Province, Vietnam  
Telephone : (84)-650-3577-507

KUBOTA Corporation

English (U.S.A.)  
Code No. K7211-7121-1